



Lichuan A4 Series AC Servo Drive

OWNER'S/OPERATOR'S MANUAL



Shenzhen Xin Lichuan Electric Co.,Ltd

Version date: 2019.02.15

CONTENTS

Chapter 1 Safety Precautions	1
Chapter 2 Electrical Specifications	2
2.1 Specification	2
2.2 Combination of drive model and motor	3
Chapter 3 Installation	4
3.1 Installation of servo drive unit	4
3.1.1 Installation environment.....	4
3.1.2 Installation method.....	4
3.1.3 Installation size.....	5
3.2 Installation of servo motor	5
3.2.1 Installation environment.....	5
3.2.2 Installation method.....	6
Chapter 4 Wiring	6
4.1 Terminal Descriptions	6
4.2 Main circuit wiring	7
4.2.1 Definition of main circuit terminal.....	7
4.2.2 Using method for main circuit power terminal (spring type).....	8
4.2.3 Main circuit wiring.....	8
4.3 Definition of wiring terminal	9
4.3.1 Definition of communication terminal (CN1/CN2)	9
4.3.2 Definition of Control Terminal (NC3).....	9
4.3.3 Definition of Encoder Terminal (NC4).....	10
4.4 Wiring principle of control signal terminal	12
4.4.1 DI Input Circuit.....	12
4.4.2 High-speed pulse input circuit.....	12
4.4.3 DO output circuit.....	13
4.4.4 Analog Input Circuit.....	14
4.4.5 Pulse Feedback Output Circuit.....	14
4.5 DI/DO port function configuration details	14
4.5.1 DI Command Description.....	14
4.5.2 DI port control mode.....	17

4.5.3 DO Command Description.....	18
Chapter 5 Description of Control Mode.....	20
5.1 Position mode description.....	20
5.1.1 Position Mode Wiring Diagram.....	20
5.1.2 Related Functions of External Position Mode.....	21
5.1.3 Position mode communication control.....	22
5.2 Speed mode description.....	24
5.2.1 Wiring diagram at speed mode.....	24
5.2.2 Related functions of external speed mode.....	25
5.2.3 Communication control switching internal speed.....	27
5.3 Torque mode specification.....	28
5.3.1 Wiring diagram of torque mode.....	28
5.3.2 Related functions of external torque mode.....	29
5.4 Gain parameter adjustment.....	31
Chapter 6 Description of parameters.....	34
6.1 Description of basic parameters.....	34
6.2 Extended Parameter Description.....	41
Chapter 7 Panel Display and Button Description.....	45
7.1 Introduction to the button interface.....	45
7.2 Schematic diagram of each mode switching.....	45
7.3 Operation instructions.....	46
7.3.1 Parameter setting.....	46
7.3.2 JOG mode.....	46
7.3.3 Initialization parameter.....	47
7.3.4 Alarm Clearing.....	48
Chapter 8 Alarm Description.....	49

Chapter 1 Safety Precautions

Before using the servo drive system, please read the precautions for the equipment carefully and follow the safety precautions and operating procedures for installation and commissioning. The company is exempt from liability for equipment damage or personal injury caused by failure to operate as required.

- ◆ This product is a general industrial product, and it is not intended for use by machines and systems involved life.
- ◆ Please engage professional qualified personnel to perform wiring, operation, maintenance and inspection.
- ◆ If it is applied to a device that may cause a major accident or loss, please equip it with a safety device.
- ◆ Although this product has considered many aspects in terms of quality management, it may cause unexpected external action due to unexpected noise, static electricity, input power, wiring, parts. Please fully consider mechanical safety measures to ensure safety within possible range of action.

Chapter 2 Electrical Specifications

2.1 Specification

Input power	CONTROL POWER	Single phase 220 VAC
	MAIN POWER SUPPLY	Single Phase/Three Phase 220VAC
Working environment	Temperature	0~45℃
	Humidity	No condensation ≤90% RH or less
	Elevation	Altitude ≤1000M
	Installation environment	Non-corrosive gases, flammable gases, oil mist or dust, etc.
	Installation method	VERTICAL INSTALLATION
Encoder feedback		2500 p/r (resolution: 10000), incremental encoder
Control signal	Digital Input	10 channels of normal digital input, with configurable function.
	Digital Output	6 channels of normal digital input, with configurable function.
Pulse signals	Input	2 high-speed inputs: differential (600K) and single-ended (200K) pulses. Support pulse input mode: PULS+DIR, A+B, CW+CCW
	Output	3-way high-speed pulse output, output signal form: 5V differential signal. 1-way Z signal single-ended output signal.
Analog quantity signal	Input	2-way analog inputs, 12-bit resolution, input range -9.5 to +9.5V. Where AI2 is fixed as the torque limit input.
	Output	None
Messaging function		RS485 communication, Modbus protocol. The main controller can control the position/speed/torque of the servo via RS485, up to 32 control stations.
Display panel and button operation		5 buttons (Mode, Set, Left, Up, Down) and 6 digital tubes
Regenerative discharge braking resistor		Built-in 100W40Ω braking resistor. An external braking resistor is required for frequent braking.

2.2 Combination of drive model and motor

LCDA4 - XX □□ ☆☆ - △□ □□

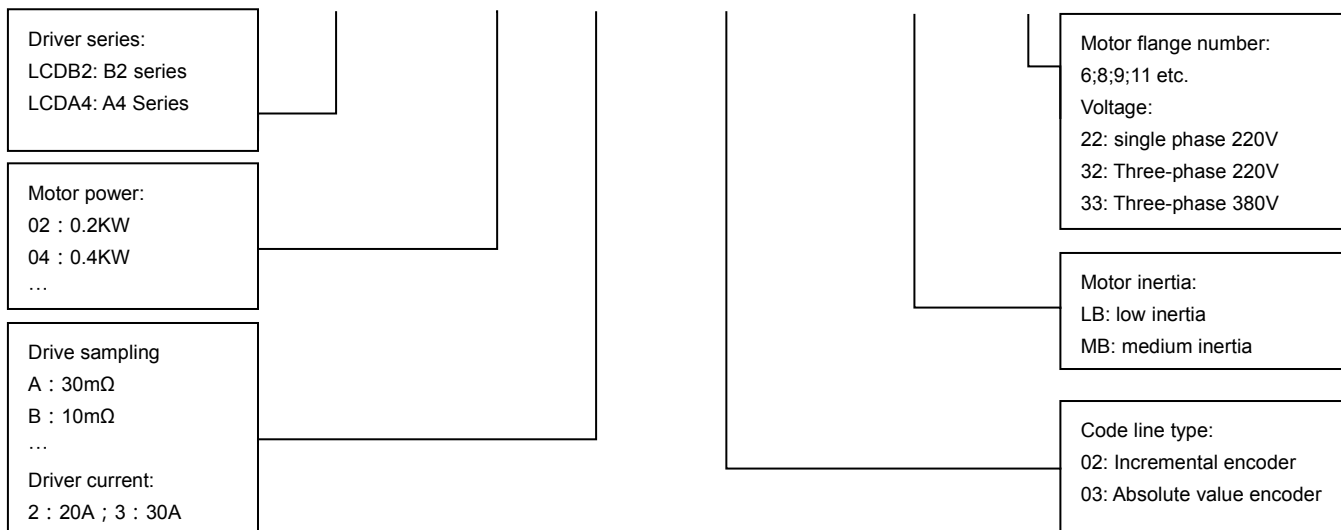

Driver model	Motor Model	Power (KW)
LCDA4-XXA2	005L02-40M00130	0.05
	01L02-40M00330	0.1
	02L02-60M00630	0.2
LCDA4-XXB2	04L02-60M01330	0.4
	06L02-60M01930	0.6
	04L02-80M01330	0.4
	07L02-80M02430	0.75
	07M02-80M03520	0.75
	07L02-90M02430	0.75
	07M02-90M03520	0.75
	06L02-110M02030	0.6
	08L02-110M04020	0.8
LCDA4-XXC2	10L02-80M04025	1.0
	10L02-90M04025	1.0
	10L02-130M04025	1.0
LCDA4-XXC3	12L02-110M04030	1.2
	15L02-110M05030	1.5
	12L02-110M06020	1.2
	18L02-110M06030	1.8
	13L02-130M05025	1.3
	15L02-130M06025	1.5
	10M02-130M10010	1.0
	15M02-130M10015	1.5
LCDA4-XXD3	20L02-130M07725	2.0
	26M02-130M10025	2.6
	23M02-130M15015	2.3

Chapter 3 Installation



Warning

- The storage and installation of the product must meet environmental conditions.
- Products that are damaged or with incomplete parts must not be installed.
- The product installation shall be made of fireproof materials and shall not be installed on or near inflammable materials to prevent fire.
- The servo drive unit must be installed in the cabinet to prevent ingress of dust, corrosive gases, conductive objects, liquids, and flammable materials.
- The servo drive unit and servo motor should be protected from vibration and must not be subjected to impact.
- Do not drag the servo motor wires and encoder wires.

3.1 Installation of servo drive unit



Note

- The servo drive unit must be installed in a well-protected electrical cabinet.
- The servo drive unit must be installed in the specified direction and spacing to ensure good heat dissipation.
- It shall not be installed on or near inflammable materials to prevent fire.

3.1.1 Installation environment

- ◆ **Use temperature/humidity:** 0 ~ 55 ° C (no frost), 90% RH or less (no condensation).
- ◆ **Storage temperature / humidity:** -20 ~ 65 ° C (no frost), 90% RH or less (no condensation).
- ◆ **Atmospheric environment:** Inside the control cabinet, no corrosive, flammable gas, oil mist, dust, etc.
- ◆ **Elevation:** below 1000m.
- ◆ **Vibration:** less than 0.5G (4.9m/s²), 10 to 60 Hz (non-continuous operation).
- ◆ **Protection:** The servo drive's own structure is unprotected, so it must be installed in a well-protected electrical cabinet to prevent intrusion of corrosive, flammable gases, conductive objects, metal dust, oil mist and liquids.

3.1.2 Installation method

- ◆ The servo drive of our company is a vertical structure, please install it vertically. The mounting direction is perpendicular to the mounting surface.
- ◆ The layout of single or multiple servo drives is shown below.

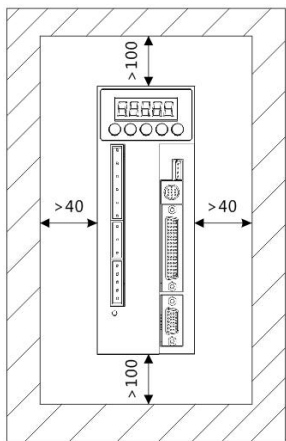

Installation interval for single servo drive unit

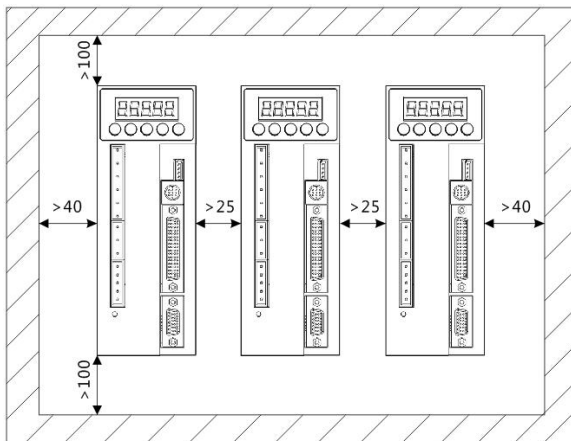

Installation interval for multiple servo units

3.1.3 Installation size

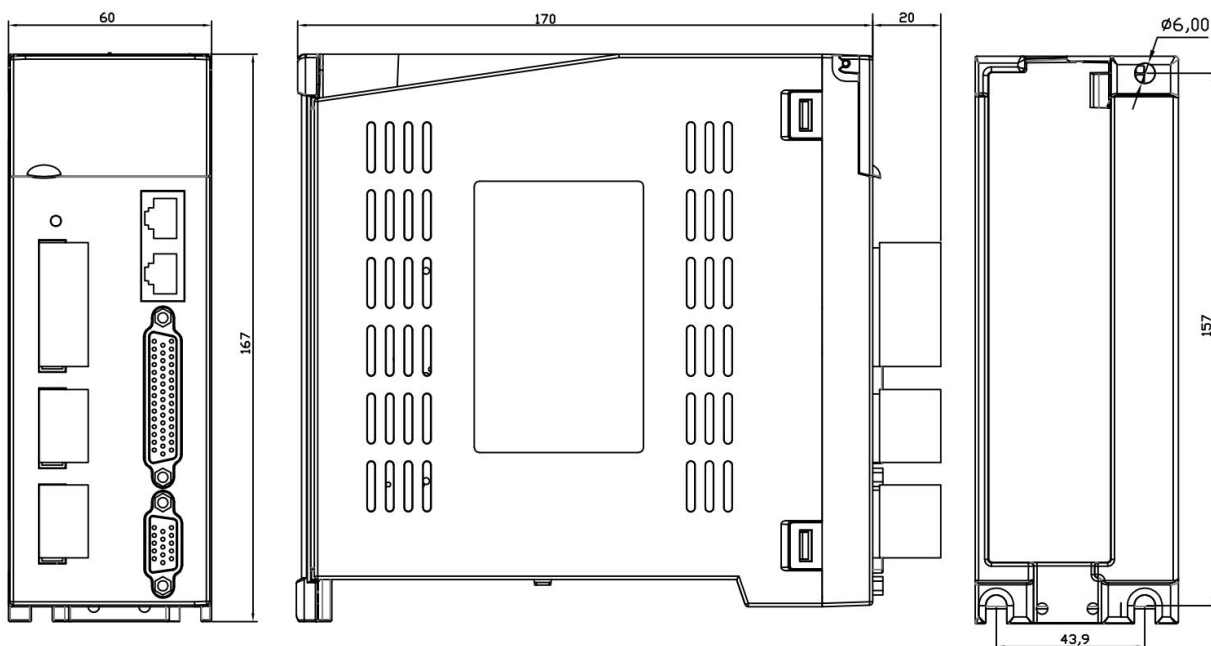

3.2 Installation of servo motor

Warning

- Do not hit the shaft end of the motor, otherwise the motor encoder may be damaged.

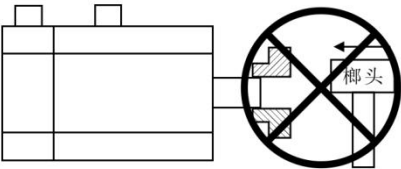

3.2.1 Installation environment

- ◆ Use temperature/humidity: 5~40° C (no frost), 90% RH or less (no condensation).

- ◆ Storage temperature / humidity: -20~55 ° C (no frost), 80% RH or less (no condensation).
- ◆ Atmospheric environment: Indoor, no corrosive, flammable gas, oil mist, dust, etc.
- ◆ **Elevation:** below 1000m.
- ◆ **Vibration:** less than 0.5G (4.9m/s²), 10 to 60 Hz (non-continuous operation).
- ◆ Protection class: IP 54

3.2.2 Installation method

- ◆ **Installation direction:** To avoid water and oil flowing from the outlet end of the motor into the motor, please place the cable outlet below. If the motor shaft is mounted upward and a reducer is attached, oil stains in the reducer shall be prevented from seeping into the motor from the motor shaft.
- ◆ **Concentric:** When connecting to a machine, use a coupling and keep the axis of the servo motor in line with the shaft of the machine.
- ◆ **Cable:** Do not bend the cable or load "tension" on it, so do not over-tighten the cable during wiring (using).
- ◆ **Fixing:** The motor must be installed securely and should be secured against loosening.

Chapter 4 Wiring



Warning

- This series of drivers is powered by three-phase 220V. When wiring, and it shall find out the power supply used by driver during wiring.
- Users must consider safety precautions during design and assembly when using this product to prevent accidents caused by incorrect operation.
- The driver terminals U, V, W must correspond to the motors U, V, W.
- The driver and motor must be well grounded.
- Power must be removed for more than 5 minutes before disassembling the drive.
- Do not turn the power on/off frequently. If the voltage must be turned on/off repeatedly, control it 1 time or less per minute.
- When using the internal braking resistor, the short-circuit wire must be connected between the B2 and B3 terminals. Do not connect the lead piece directly between B1 and B2.

4.1 Terminal Descriptions

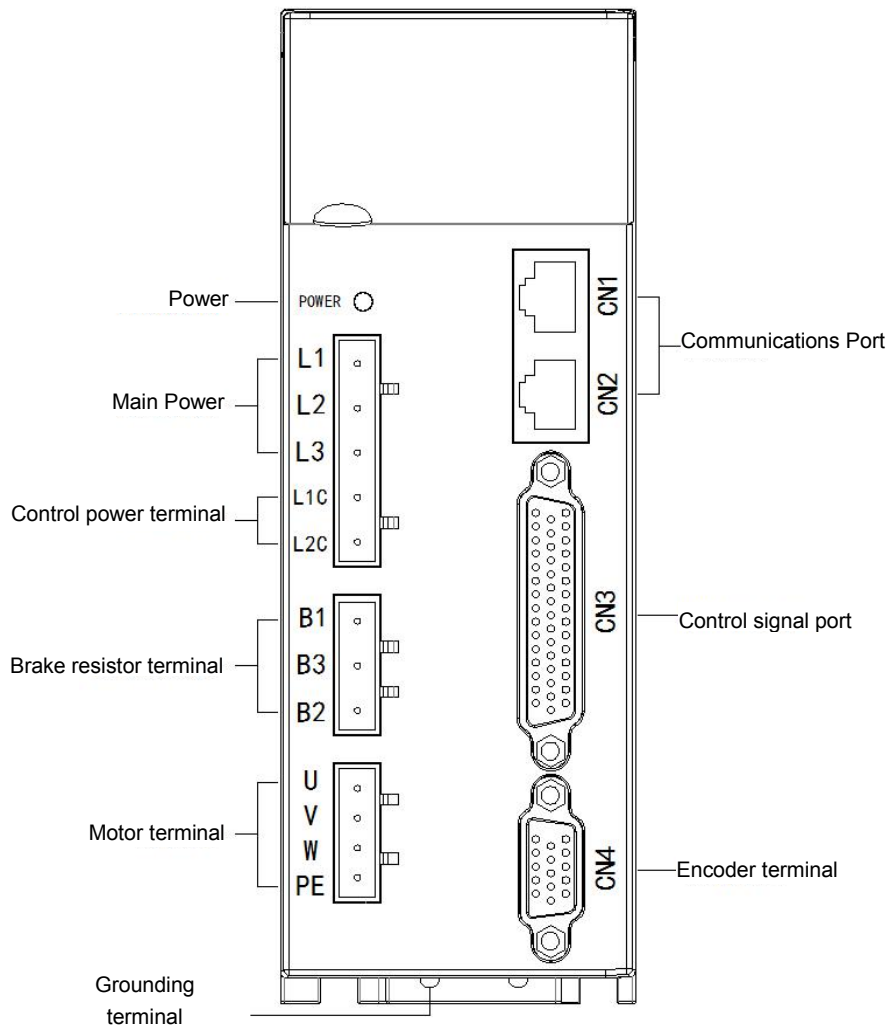

4.2 Main circuit wiring

4.2.1 Definition of main circuit terminal

◆ Input power terminal

No.	Signal definition	Feature
1	L1	Main circuit power supply, and it can be connected to three-phase 220V or single-phase 220V
2	L2	
3	L3	
4	L1C	Control power supply 220V AC input L1C
5	L2C	Control power supply 220V AC input L2C

◆ Brake resistor terminal

Pin	Signal definition	Feature	Descriptions
1	B1	DC bus positive terminal output DCP	The built-in resistor is terminated with B1 at positive end. If use built-in resistor to form B2 and B3 short circuit. If use external resistor, please connect the resistor between B1 and B2 (B2 and B3 must be disconnected).
2	B3	Built-in brake resistor negative output.	
3	B2	Brake triode collector output	

◆ **Motor terminal**

No.	Signal definition	Feature
1	U	Connected to the motor U phase
2	V	Connected to the motor V phase
3	W	Connected to the motor W phase
4	PE	Connected to the motor housing

4.2.2 Using method for main circuit power terminal (spring type)

1. Strip the wire sheath to expose 8~9mm bare copper wire.
2. The line pressing method is as follows:
 - Use the control lever of the servo drive to open the slot (as shown in Figure A);
 - Insert a straight screwdriver into the terminal opening (end width 3.0 to 3.5 mm), and press it firmly to open the slot (as shown in Figure B).
3. The line pressing method is as follows:

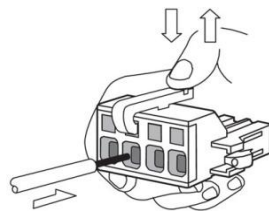

Figure a

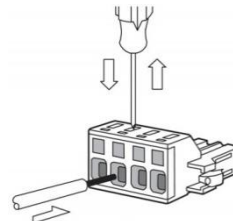
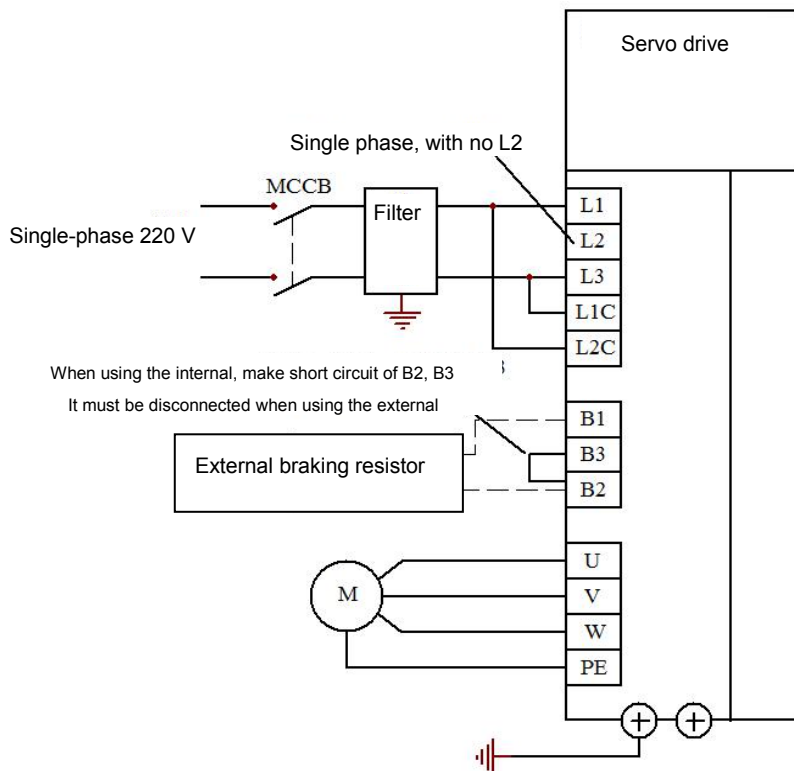

Figure b

4.2.3 Main circuit wiring

1. Single-phase power supply wiring:



2. Three-phase power supply wiring:

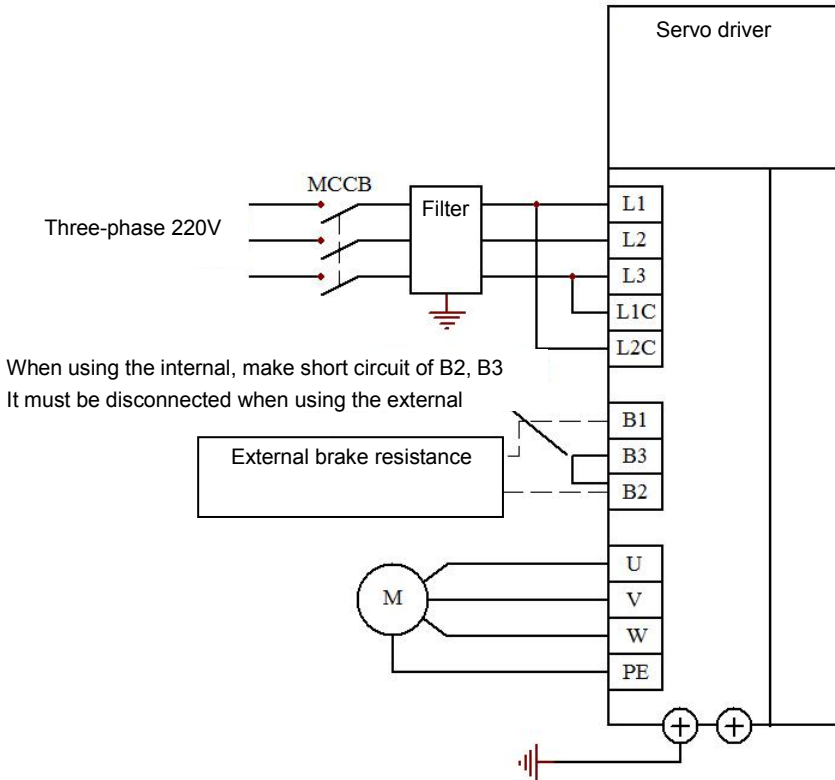

Note: When using the internal braking resistor, make short circuit of B2 and B3 (it has been factory connected); when using the external braking resistor, disconnect B2 and B3, and connect external braking resistor between B1 and B2.

4.3 Definition of wiring terminal

4.3.1 Definition of communication terminal (CN1/CN2)

Pin	Cable color	Signal definition
1	White/orange	CAN+
2	Orange	CAN-
3	White green	GND
4	Blue	485+
5	White/blue	485-
6	Green	NC
7	White/brown	NC
8	Brown	NC

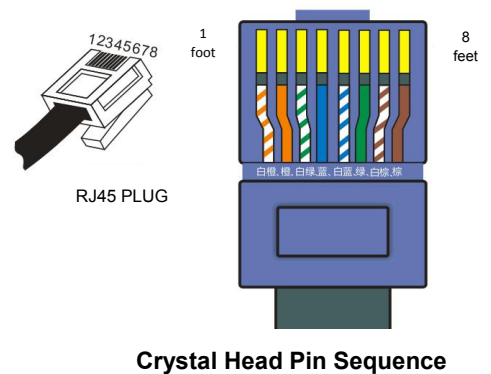

4.3.2 Definition of Control Terminal (NC3)

Pin	Signal description	Function Name	Precautions or supplementary notes
1	PUL-	Pulse input PUL negative terminal. 5V interface.	When the 5V pulse interface is connected to a 12V or 24V pulse, an external resistor must be connected in series;
2	PUL+	Pulse input PUL positive	

		terminal. 5V interface.	When using the 24V pulse input common port, the 24V collector pulse signal can be directly connected.
16	DIR-	Pulse direction DIR negative terminal. 5V interface.	
17	DIR+	Pulse direction DIR positive terminal. 5V interface.	
35	OPC	24V pulse input common terminal	
3	DI0	Digital input 0.	For detailed description of the parameter configuration, see page 13 Chapter 4.5.1.
4	DI1	Digital Input 1	
5	DI2	Digital input 2.	
6	DI3	Digital input 3.	
18	DI4	Digital input 4.	
19	DI5	Digital input 5.	
20	DI6	Digital input 6.	
21	DI7	Digital input 7.	
36	COM+	DI port external power input positive terminal	It shall be connected to external +24V
37	COM-	DI/DO port external power input negative terminal	It shall be connected to external 0V
7	DO0	Digital input 0	For detailed description of the parameter configuration, see page 15 Chapter 4.5.3.
8	DO1	Digital input 1	
22	DO2	Digital input 2	
23	DO3	Digital input 3	
38	DO4	Digital input 4	
39	DO5-	Digital input 5-	
40	DO5+	Digital input 5-	
9	A+	Encoder frequency dividing output A+	Related configuration parameters: PA_044: feedback pulse doubling molecule PA_045: feedback pulse division octave denominator PA_046: Feedback pulse logic inversion
10	A-	Encoder frequency dividing output A-	
11	B+	Encoder frequency dividing output B+	
12	B-	Encoder frequency dividing output B-	
13	Z+	Encoder frequency dividing output Z+	
14	Z-	Encoder frequency dividing output Z-	
15	CZ	Z signal set electrode output end	Z signal set electrode output
24	GND	Feedback pulse output power ground	
41	AGND	Analog Input AGND	An external analog input that can be used as a speed or torque input signal.
42	AI1	Analog input AI1	
43	AGND	Analog Input AGND	External analog input can only be taken as a torque limit input signal.
44	AI2	Analog input AI2	
33	485R1	485 bus end resistor short jumper	Make short circuit of the last servo of the 485 bus
34	485R2		

4.3.3 Definition of Encoder Terminal (NC4)

◆ Interface Schematic

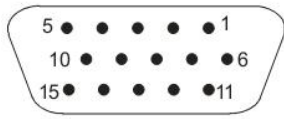

Servo side DB15 connector

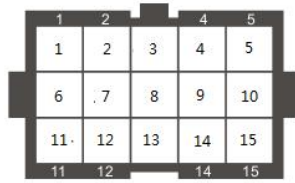

Small inertia motor ampere connector

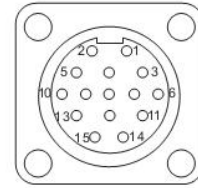

Medium inertia motor aviation plug

◆ Motor docking of aviation joints (Flange 110/130 motor)

Servo side DB15 pin	Motor side aviation plug pin	Name	Wire color selection		
1	B+	5	B+	Encoder signal B+	Orange black
2	Z+	6	Z+	Encoder signal Z+	Yellow and black
3	U+	10	U+	Hall signal U+	Br/B
4	V+	11	V+	Hall signal V+	Green and black
5	GNDD	3	GNDD	Encoder power ground	Black
6	A-	7	A-	Encoder signal A-	White
7	B-	8	B-	Encoder signal B-	Orange
8	Z-	9	Z-	Encoder signal Z-	Yellow
9	U-	13	U-	Hall signal U-	Brown
10	V-	14	V-	Hall signal V+	Green
11	VCC	2	VCC	Encoder power +5V	Red
12	A+	4	A+	Encoder signal A+	W/B
13	Casings	1	Casings	Shield ground	Shield ground
14	W+	12	W+	Hall signal W+	Gr/B
15	W-	15	W-	Hall signal W-	Grey

◆ Docking with Amp plug motor (Flange 40/60/80 motor)

Servo side DB15 pin	Motor side interface pin	Name	Wire color selection		
1	B+	4	B+	Encoder signal B+	Orange black
2	Z+	7	Z+	Encoder signal Z+	Yellow and black
3	U+	6	U+	Hall signal U+	Br/B
4	V+	10	V+	Hall signal V+	Green and black
5	GNDD	3	GNDD	Encoder power ground	Black
6	A-	13	A-	Encoder signal A-	White
7	B-	14	B-	Encoder signal B-	Orange
8	Z-	5	Z-	Encoder signal Z-	Yellow
9	U-	8	U-	Hall signal U-	Brown
10	V-	12	V-	Hall signal V-	Green
11	VCC	2	VCC	Encoder power +5V	Red
12	A+	9	A+	Encoder signal A+	W/B
13	Casings	1	Shield ground	Shield ground	Shield ground
14	W+	11	W+	Hall signal W+	Gr/B
15	W-	15	W-	Hall signal W-	Grey

4.4 Wiring principle of control signal terminal

4.4.1 DI Input Circuit

- ◆ NPN type input

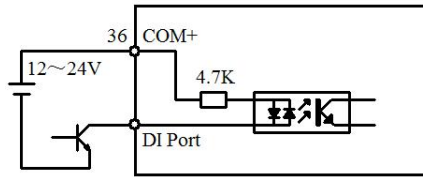

- ◆ PNP type input

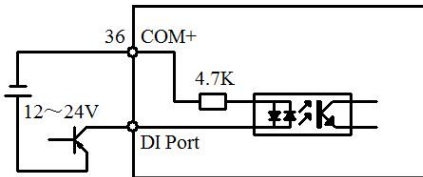

- ◆ Relay or switch input

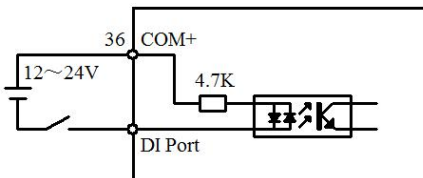

4.4.2 High-speed pulse input circuit

- ◆ Differential pulse signal

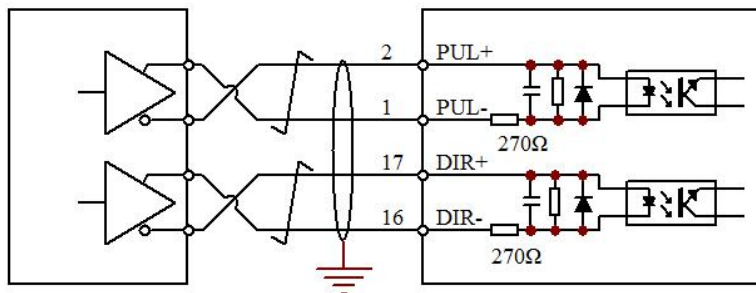

- ◆ NPN pulse signal (external resistor)

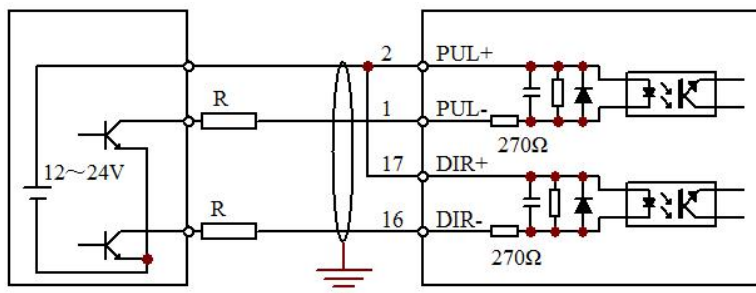

- ◆ PNP pulse signal (external resistor)

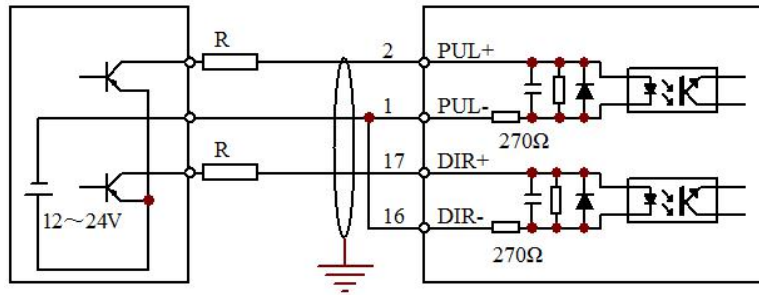

◆ 24V NPN pulse signal (built-in resistor)

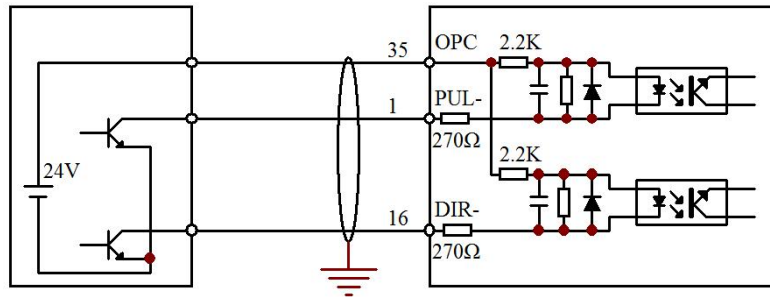

Note: When making wiring with external resistor, if the external signal voltage is 24V, R=2K; if the external signal voltage is 12V, R=1K.

4.4.3 DO output circuit

◆ DO~DO4 output circuit (common output negative terminal)

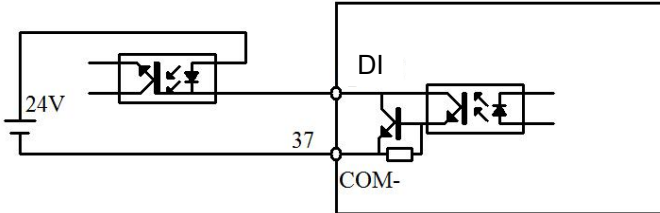

Optocoupler output

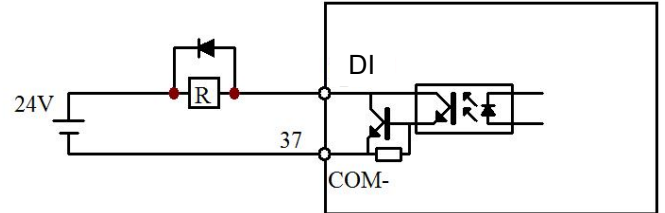

Relay output

◆ DO5 output circuit (Independent positive and negative output terminal)

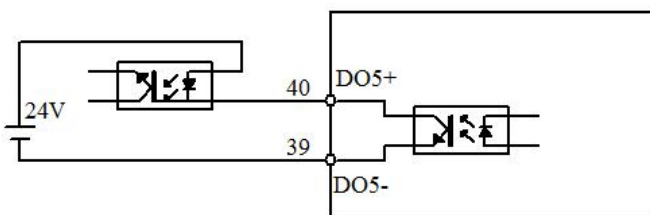

Optocoupler low level output

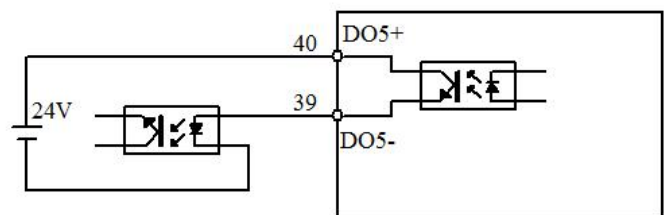

Optocoupler high level output

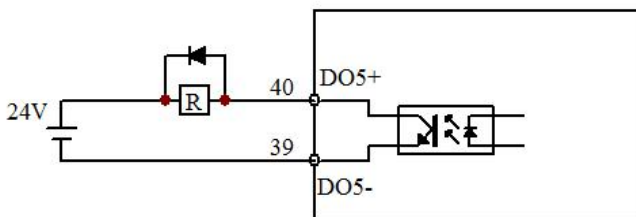

Relay Driver Outputs (100mA)

4.4.4 Analog Input Circuit

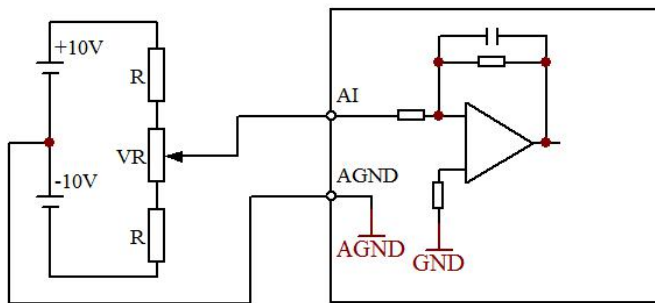

4.4.5 Pulse Feedback Output Circuit

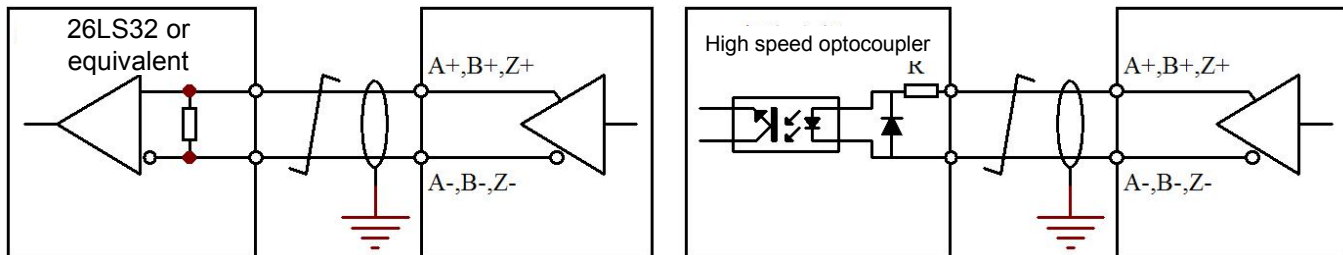

4.5 DI/DO port function configuration details

4.5.1 DI Command Description

1. Each digital input DI can be configured as any servo command.
2. Relevant Parameters:

Parameter number	Parameter Functionality	Mode	Range	initial value	Description of parameters
PA_080	DI0 configuration	P/S/T	0~22	0	Servo enabling (It can change the function by modifying the parameter value)
PA_081	DI1 configuration	P/S/T	0~22	1	Alarm clearing (It can change the function by modifying the parameter value)
PA_082	DI2 configuration	P/S/T	0~22	2	Clockwise stroke limit (change function by modifying parameter values)
PA_083	DI3 configuration	P/S/T	0~22	3	Counterclockwise travel limit (It can change the function by modifying the parameter value)
PA_084	DI4 configuration	P/S/T	0~22	10	Deviation counter clearing to 0 (It can change the function by modifying the parameter value)
PA_085	DI 5 Configuration	P/S/T	0~22	8	Command pulse prohibition (It can change the function by modifying the parameter value)
PA_086	DI6 configuration	P/S/T	0~22	15	Torque limit switching (It can change the function by modifying the parameter value)
PA_087	DI7 configuration	P/S/T	0~22	16	Back to zero start position (It can change the function by modifying the parameter value)
PA_08E	IO polarity configuration	P/S/T		0	The lower 8 bits correspond to the polarity configuration of the DI input port. Bit0 corresponds to DI0. The higher 8 bits correspond to the polarity configuration of the DI output port. Bit8 corresponds to DO0

3. DI servo command table

Command number (Set value of DI configuration parameter)	Command symbol	Command Name	Applicable control mode	Function or notes												
0	SRV-ON	Servo enabling	P/S/T	<p>1. When the command is valid, the servo enters the enable state (i.e. the motor is energized)</p> <p>2. When the command is invalid, the servo cannot be enabled; i.e., the motor is not powered.</p> <p>Notice:</p> <p>3. After the command is valid, the pulse can be input after at least 100mS.</p> <p>4. Do not use this command to start or stop the motor</p>												
1	A-CLR	Alarm release	P/S/T	<p>1. When the command continues to be valid for 120ms, the alarm status can be cleared.</p> <p>2. When the alarm is cleared, the deviation counter will also be cleared.</p> <p>Notice:</p> <p>3. Some alarm states cannot be cleared by this command. Such as over-current alarm</p>												
2	CWL	Clockwise stroke limit	P/S/T	<p>This command indicates the stroke limit signal in the CW (clockwise) direction. When the moving part exceeds the stroke limit switch in the CW direction, the signal is valid, so that the torque in the CW direction will no longer be generated.</p> <p>PA_004 can set whether the command is valid PA_066 can set the action when this command is valid.</p>												
3	CCWL	Anticlockwise stroke limit	P/S/T	<p>This command indicates the stroke limit signal in the CCW (Counterclockwise) direction. The function is the same as CWL, refer to CWL.</p>												
4	C-MODE	Control mode switching	P/S/T	<p>If the parameter PA_002 (control mode parameter) is set to 3 to 5, the control mode is selected as follows:</p> <table border="1" style="margin-left: auto; margin-right: auto;"> <thead> <tr> <th>PA_002 Value</th> <th>C-MODE Invalid</th> <th>C-MODE Valid</th> </tr> </thead> <tbody> <tr> <td>3</td> <td>Position control</td> <td>Speed Control</td> </tr> <tr> <td>4</td> <td>Position control</td> <td>Torque control</td> </tr> <tr> <td>5</td> <td>Speed Control</td> <td>Torque control</td> </tr> </tbody> </table> <p>Note: When using the C-Mode switching mode, the motor may run sharply due to different commands in the corresponding control mode.</p>	PA_002 Value	C-MODE Invalid	C-MODE Valid	3	Position control	Speed Control	4	Position control	Torque control	5	Speed Control	Torque control
PA_002 Value	C-MODE Invalid	C-MODE Valid														
3	Position control	Speed Control														
4	Position control	Torque control														
5	Speed Control	Torque control														
5	ZEROSPD	Zero speed clamp	S/T	<p>When the signal is valid, the servo speed is forced to 0 rpm. PA_006 can set whether the command is valid.</p>												

6	DIV	Command pulse frequency selection	P	Valid in position control mode. When the DIV is valid, the electronic gear ratio numerator selects the second command pulse frequency dividing molecule PA_049; and when the DIV is invalid, the first command pulse frequency dividing molecule PA_048 is selected.																									
7	SPD_DIR	Speed command direction	S	Valid in speed control mode. Indicates the direction of the analog speed command. This command is valid by setting PA_006.																									
8	INH	Command pulse prohibition	P	When this command is active, the input of the position pulse command is shielded. PA_043 (instruction pulse forbids invalid setting) can set whether this command is valid.																									
9	GAIN	Gain switching	P/S	<table border="1"> <thead> <tr> <th>PA_031 PA_032</th> <th>PA_030</th> <th>GAIN</th> <th>Feature</th> </tr> </thead> <tbody> <tr> <td rowspan="2">/</td> <td>0</td> <td>0</td> <td>Speed loop PI control</td> </tr> <tr> <td>0</td> <td>1</td> <td>Speed loop PI control</td> </tr> <tr> <td rowspan="2">PA_031=2 PA_032=2</td> <td rowspan="2">1</td> <td>0</td> <td>Select the first gain</td> </tr> <tr> <td>1</td> <td>Select the second gain</td> </tr> <tr> <td>PA_031≠2 PA_032≠2</td> <td>1</td> <td colspan="2">invalid</td> </tr> </tbody> </table>	PA_031 PA_032	PA_030	GAIN	Feature	/	0	0	Speed loop PI control	0	1	Speed loop PI control	PA_031=2 PA_032=2	1	0	Select the first gain	1	Select the second gain	PA_031≠2 PA_032≠2	1	invalid					
PA_031 PA_032	PA_030	GAIN	Feature																										
/	0	0	Speed loop PI control																										
	0	1	Speed loop PI control																										
PA_031=2 PA_032=2	1	0	Select the first gain																										
		1	Select the second gain																										
PA_031≠2 PA_032≠2	1	invalid																											
10	CL	Clear the deviation counter to 0	P/S/T	<p>It can be used to clear the contents of the deviation counter to 0.</p> <p>Use PA_04E (counter clearing 0 mode parameter) to set:</p> <p>0: The position deviation counter can be cleared to 0 by level (CL and COM - at least 100uS short circuit).</p> <p>1: Make clearing with a rising edge (open circuit -> short circuit at least 100uS).</p> <p>2: This function is invalid, so block this function</p>																									
11	INTSPD1	Internal command selection 1	P/S/T	<p>When the servo command is given as a multi-segment internal command, the sequence number selected by the command is determined by the binary value consisting of INTSPD1~INTSPD4, as shown in the following table:</p> <table border="1"> <thead> <tr> <th>INTSP D4</th> <th>INTSP D3</th> <th>INTSP D2</th> <th>INTSP D1</th> <th>Command No.</th> </tr> </thead> <tbody> <tr> <td>0</td> <td>0</td> <td>0</td> <td>0</td> <td>0</td> </tr> <tr> <td>0</td> <td>0</td> <td>0</td> <td>1</td> <td>1</td> </tr> <tr> <td>...</td> <td>...</td> <td>...</td> <td>...</td> <td>...</td> </tr> <tr> <td>1</td> <td>0</td> <td>0</td> <td>0</td> <td>8</td> </tr> </tbody> </table>	INTSP D4	INTSP D3	INTSP D2	INTSP D1	Command No.	0	0	0	0	0	0	0	0	1	1	1	0	0	0	8
INTSP D4	INTSP D3	INTSP D2	INTSP D1		Command No.																								
0	0	0	0		0																								
0	0	0	1		1																								
...																									
1	0	0	0	8																									
12	INTSPD2	Internal command selection 2	P/S/T																										
13	INTSPD4	Internal command selection 4	P/S/T																										
14	INTSPD3	Internal command selection 3	P/S/T																										

15	TL-SEL	Torque limit switchover	P/S/T	<p>This command allows you to select different torque limit values.</p> <p>You can set this command to be valid by PA_003 parameter.</p> <table border="1"> <thead> <tr> <th>PA_003</th> <th>CCW (counterclockwise)</th> <th>CW (clockwise)</th> </tr> </thead> <tbody> <tr> <td>1</td> <td colspan="2">CCW and CW direction limit value is set by PA_05E</td> </tr> <tr> <td>2</td> <td>Set by PA_05E</td> <td>Set by PA_05F</td> </tr> <tr> <td>3</td> <td colspan="2">TL-SEL signal is invalid, set by PA_05E TL-SEL signal is valid, set by PA_05F</td> </tr> </tbody> </table>	PA_003	CCW (counterclockwise)	CW (clockwise)	1	CCW and CW direction limit value is set by PA_05E		2	Set by PA_05E	Set by PA_05F	3	TL-SEL signal is invalid, set by PA_05E TL-SEL signal is valid, set by PA_05F	
				PA_003	CCW (counterclockwise)	CW (clockwise)										
				1	CCW and CW direction limit value is set by PA_05E											
				2	Set by PA_05E	Set by PA_05F										
3	TL-SEL signal is invalid, set by PA_05E TL-SEL signal is valid, set by PA_05F															
16	Homing	Start position of "back to zero"	P	<p>The rising edge of the command initiates the mechanical zero return action.</p> <p>Related parameter reference of "back to zero": PA_0A0 ~ PA_0A6</p>												
17	ORG_SW	Origin switch position	P	<p>This command signal is useful when the servo is zeroed. The command signal is valid, indicating that the machine has reached the origin switch.</p>												
18	POS_LOCK	Servo locking	P	<p>This command is valid. The servo force forces the motor to the position corresponding to the valid command, and the given command is ignored.</p>												
19	JOG_BIT	JOG starting position	P/S/T	<p>If the command is valid, the servo starts JOG action.</p>												
20	POS_LOAD	Position loading signal	P	<p>When the command is valid, the new position command will be reloaded.</p> <p>Corresponding parameters: PA_096 multi-segment position loading mode setting parameter</p>												
21	EMG	Emergency stop or external error input	P/S/T	<p>If the command is valid, the servo stops immediately. This signal has a higher priority than the servo enabling. That is, SERV-ON is valid, but EMG is also effective, then the motor is not powered.</p>												

4.5.2 DI port control mode

1. External DI port control

The DI can be controlled by wiring according to the wiring diagram in Chapter 5.

2. Communication control DI port

Setting the bit corresponding to PA_1A0 can determine whether the corresponding DI port is controlled by external wiring or communication parameter PA_1A4.

PA_1A5 can mask the status change of the corresponding bit of the PA1A4 parameter, as shown in the following example:

Parameter number	Parameter Functionality	Parameter value binary bit status							
		DI7	DI6	DI5	DI4	DI3	DI2	DI1	DI0
PA_1A0	External IO/Analog IO Switching	0	1	0	1	0	0	1	0
	When the corresponding bit is set to 0, the corresponding DI port is controlled by external wiring; When it is set to 1, the corresponding DI port is controlled by analog IO, with the control parameter of PA_1A4.	External control	COMM UNI-CATION CONTROL	External control	COMM UNI-CATION CONTROL	External control	External control	COMM UNI-CATION CONTROL	External control
PA_1A5	Communication analog IO masking	0	0	0	0	0	0	1	0
	When the corresponding bit of this parameter is set to 1, the status of the corresponding bit of PA_1A4 can be masked.							Mask	
PA_1A4	Communication simulation IO	0	0	0	1	0	1	1	0
	When the corresponding bit of PA_1A0 is set to 1, this parameter can modify the status of the corresponding DI port. When it is set to 1, it indicates that the DI port is valid.	External control	DI OFF	External control	DI On	External control	External control	DI OFF	External control

4.5.3 DO Command Description

1. Each digital output DO can be configured to indicate any servo output status (serial number). Relevant parameters:

Parameter number (hexadecimal)	Parameter name	related Mode	Setting Range	Defaults	Function and meaning
PA_088	DO0 indication configuration	P/S/T	0~17	0	Servo ready
PA_089	DO1 indication configuration	P/S/T	0~17	1	Servo alarm
PA_08A	DO2 indication configuration	P/S/T	0~17	2	Location arrival
PA_08B	DO3 indication configuration	P/S/T	0~17	3	Brake Release
PA_08C	DO4 indication configuration	P/S/T	0~17	4	Zero speed detection
PA_08D	DO5 indication configuration	P/S/T	0~17	5	Torque limit arrival

2. Table of DO port function configuration

State no. (DO configuration value)	Status symbols	State Name	Function or meaning
0	S-RDY	Servo ready	1: The servo is ready, as long as it is enabled, it can be powered 0: The servo has an alarm or the main power is not powered on.
1	ALM	Servo alarm	1: Servo has an alarm 0: Servo has no alarm
2	COIN	Location arrival	1: Positioning completed 0: The location has not been arrived
3	BRK-OFF	Brake Release	1: The brake is released, the brake is released, and the motor shaft can be freely loosened. 0: The brake release is invalid; the motor is tight and cannot be rotated.
4	ZSP	Zero speed detection	1: Servo speed is close to zero speed (< PA_061 setting value) 0: Servo speed is not 0 (>PA_061 setting value).
5	TLC	Torque limiting	1: The actual torque is greater than the setting limiting torque value. 0: The actual torque is less than the setting limited torque value.
6	V-COIN	Speed consistency	1: The actual speed differs lightly from the given speed value, that is, the speed deviation is small. 0: The actual speed differs greatly from the given speed value, that is, the speed deviation is very large.
7	AT-SPEED	Speed arrival	1: Actual speed absolute value > Specified speed PA_062 0: Actual speed absolute value < Specified speed PA_062
9	OVERLOAD_O	OVERLOAD WARNING	1: Servo with overload alarm 0: Servo with no overload
10	BRAKE_ON	Brake pipe conduction state	1: Servo brake transistor conduction, and bus voltage is discharging through the resistor 0: Servo brake transistor closing.
11	ORG_FOUND	Origin has been found	during the servo mechanical back to zero 1: Means the origin has been found 0: Means the origin has not been found
14	BRAKE_ON_ERR_O	Brake error message	1: Too large servo braking force warning 0: No excessive braking rate of servo
15	EEPROM_STATE_O	EEPROM completion status	During the process of EEPROM reading and writing, 1: indicates EEPROM reading and writing have been completed 0: indicates EEPROM reading and writing have not been completed
16	JOG_RUN	JOG running position	1: indicates it is in trial operation 0: Not in the trial operation.
17	Homing_activated	Servo back to zero status	1: zero return action is running 0: Zero return action is not started

Chapter 5 Description of Control Mode

5.1 Position mode description

5.1.1 Position Mode Wiring Diagram

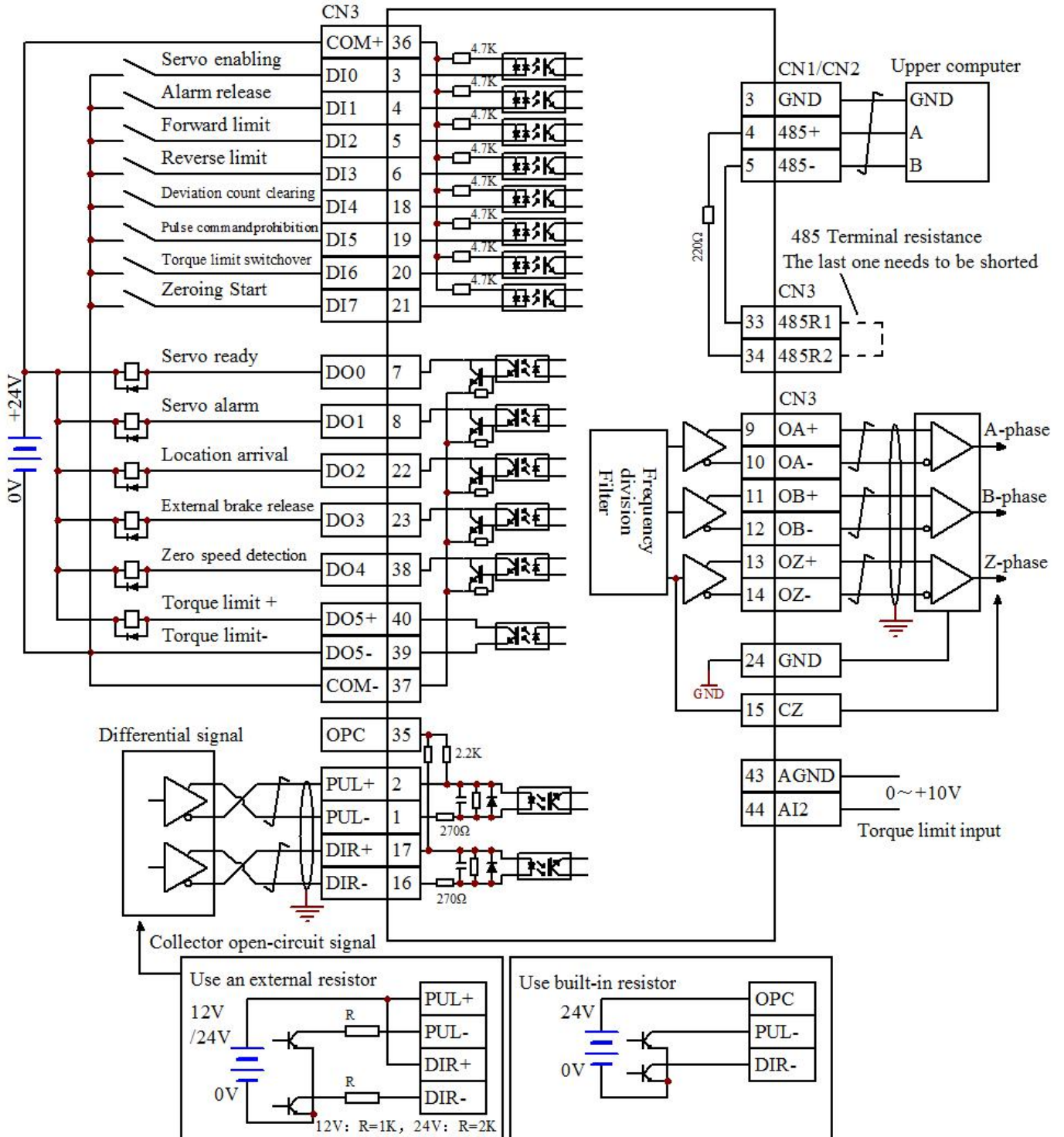

Note: When the servo is enabled, it can be controlled by the external DI port or powered on by PA_08F. The motor must be enabled before it can be controlled.

The DI port and D0 port functions of this wiring diagram are not the default configuration of the servo, and the I0 function parameters need to be modified.

5.1.2 Related Functions of External Position Mode

1. Pulse pin

Signal description	Corresponding CN3 pin number	Name	Notes or supplementary notes
PUL+	2	Pulse input positive.	1.2K current limiting resistor must be connected when connecting 24V pulse 2.Related parameters, PA_041, PA_042
PUL-	1	Pulse input negative.	
DIR+	17	Positive pulse direction	1.2K current limiting resistor must be connected when connecting 24V pulse 2. Related parameters, PA_041, PA_042
DIR-	16	Pulse direction negative.	
OPC	35	24V pulse common terminal	When the 24V pulse is input, the built-in resistor can be used through this terminal.

2. Related parameters

Parameter number	Parameter name	Setting range	Feature
PA_002	Control mode selection	0~5	When it is set to 0, it is the position mode
PA_041	Command pulse direction	0~1	Set the direction of the input pulse command
PA_042	Command pulse input form	0~3	Set the type of input pulse command 0 or 2: AB orthogonal pulse 1: CW + CCW pulse 3: pulse + direction
PA_04A	Number of pulses per motor	0~32767	Set the number of pulses per revolution of the motor directly. When this parameter is 0, the gear ratio will take effect.
PA_048	Electronic gear ratio molecule 1	1~10000	When the parameter PA_04A is set to 0, the electronic gear ratio can take effect. The electronic gear ratio molecule 1 is default to be effective. Number of pulses per revolution = $\frac{\text{electronic gear ratio denominator} \times 10000}{\text{electronic gear ratio molecule}}$
PA_049	Electronic gear ratio molecule 2	1~10000	
PA_04B	Electronic gear ratio denominator	1~10000	
PA_04C	Position smoothing filter	0~7	Set position command smoothing filter 0: The filter is not effective; 1~7: The filter is valid. The larger the value, the higher the position command delay.
PA_045	Feedback pulse division factor	0~32767	0: number of feedback pulses per revolution = encoder resolution × 4 When it is not 0: Number of feedback pulses per revolution = $\frac{(\text{encoder resolution} \times 4)}{\text{PA}_045}$
PA_046	Feedback pulse logic	0~7	Bit0: Set the logic level of the feedback pulse B signal

	inversion		Bit1: Set the logic level of the feedback pulse Z signal Bit2: Feedback pulse output content selection
PA_08F	Servo enable mode configuration	0~1	0: External command or communication command enabling 1: Power-on automatic enabling

3. DI/DO port function configuration

See section 4.5 of DI/DO command details.

5.1.3 Position mode communication control

1. DI port function configuration

Parameter number	Parameter name	Set point	Feature
PA_080	DI0 function configuration	0	Servo enabling
PA_081	DI1 function configuration	1	Alarm release
PA_082	DI2 function configuration	2	Clockwise stroke limit
PA_083	DI3 function configuration	3	Anticlockwise stroke limit
PA_084	DI4 function configuration	21	Emergency stop
PA_085	DI5 function configuration	20	Position loading signal
PA_086	DI6 function configuration	17	Origin switch
PA_087	DI7 function configuration	16	Start of "back to zero"

2. Related pin wiring

Signal description	Corresponding CN3 pin number	Name	Notes or supplementary notes
CWL	5	Clockwise stroke limit	DI port function should be configured first
CCWL	6	Anticlockwise stroke limit	DI port function should be configured first
ORG_SW	20	Origin switch	DI port function should be configured first

3. Related parameters

Parameter number	Parameter name	Setting range	Feature
PA_002	Control mode selection	0~5	When it is set to 0, it is the position mode
PA_090	Work mode settings	0~1	0: External control 1: Extended control (It is set to 1 when using communication control)
PA_091	Communication location mode index	0~15	When the DI port is configured with the NTSPD1~INTSPD4 function, the external DI port is required to switch the position segment to be loaded;

			<p>When the DI port is not configured with the INTSPD1~INTSPD4 function, this parameter can be used to select the position segment to be loaded.</p> <p>Example: When it is set to 2, the internal position of the second segment is loaded.</p> <p>When the load signal is triggered, the motor rotates according to the internal position of the second segment.</p>								
PA_094	Absolute position or relative position setting	0~1	<table border="1"> <thead> <tr> <th>PA_096</th> <th>PA_094</th> <th>Functional description</th> </tr> </thead> <tbody> <tr> <td rowspan="2">0</td> <td>0</td> <td>Loading</td> </tr> <tr> <td>1</td> <td>Loading</td> </tr> </tbody> </table>	PA_096	PA_094	Functional description	0	0	Loading	1	Loading
			PA_096	PA_094	Functional description						
0	0	Loading									
	1	Loading									
PA_096	Multi-segment position loading mode	0~2	<table border="1"> <tbody> <tr> <td rowspan="2">1</td> <td>0</td> <td>High level loading</td> </tr> <tr> <td>1</td> <td>Not supported (load signal is invalid)</td> </tr> </tbody> </table>	1	0	High level loading	1	Not supported (load signal is invalid)			
			1		0	High level loading					
				1	Not supported (load signal is invalid)						
			2	0	Rising edge loading						
1	Rising edge loading										

PA_0A0	Power-on zero returning setting	0~1	0: The Homing signal triggers zero returning. 1: Power-on automatic zero returning.
PA_0A1	Zero returning mode setting	0~1	Refer to the appendix for a description of the zero returning function.
PA_170	Internal position command 0	Any	The number of displacement pulses corresponding to the internal position 15.
...
PA_19F	Internal position command speed 15	0~3000	The speed corresponding to the internal position 15.

5.2 Speed mode description

5.2.1 Wiring diagram at speed mode

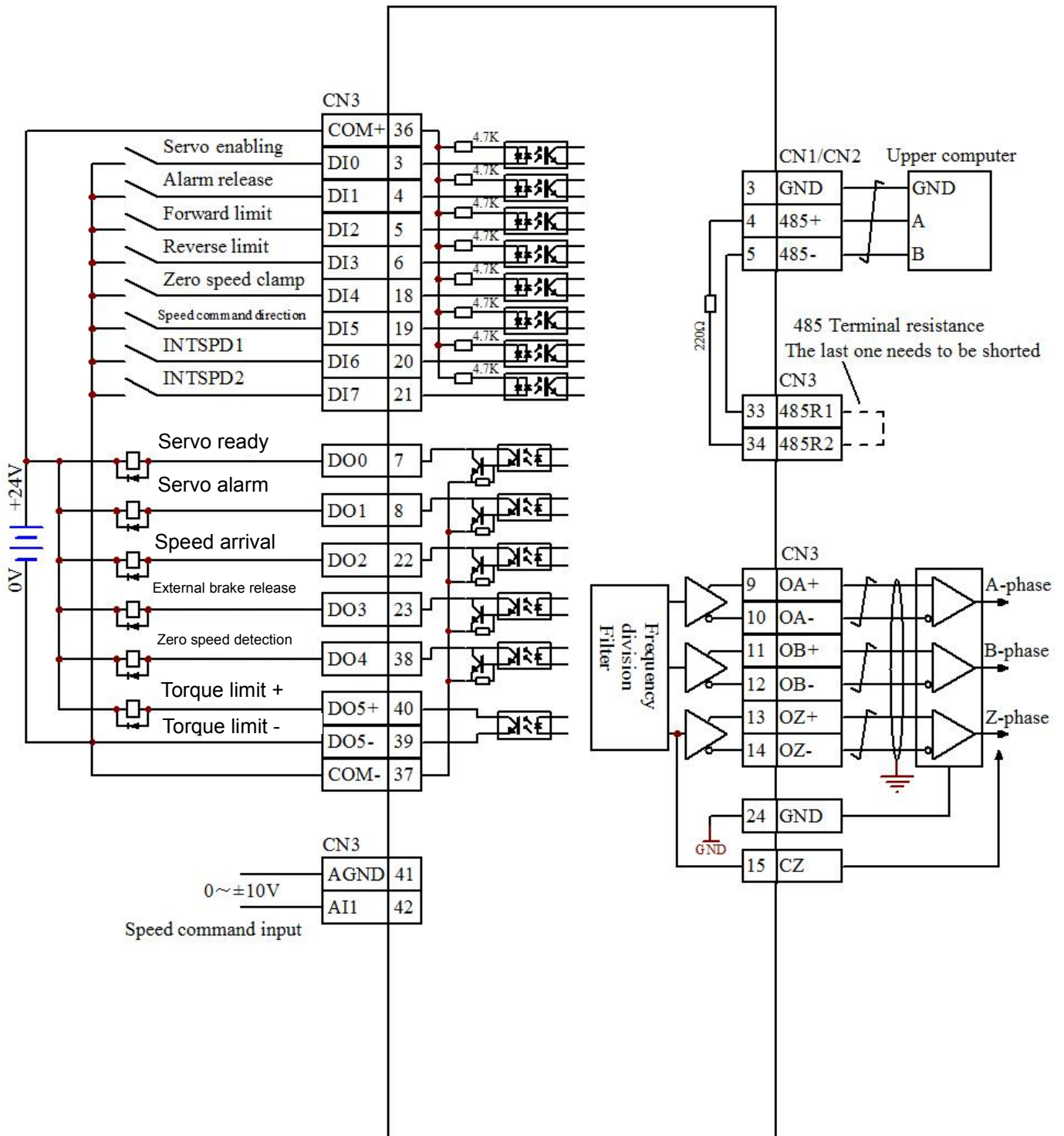

Note: When the servo is enabled, it can be controlled by the external DI port or powered on by PA_08F. The motor must be enabled before it can be controlled. The DI port and DO port functions of this wiring diagram are not the default configuration of the servo, and the IO function parameters need to be modified.

5.2.2 Related functions of external speed mode

1. DI/D0 port function configuration

Parameter number	Parameter name	Set point	Feature
PA_080	DI0 function configuration	0	Servo enabling
PA_081	DI1 function configuration	1	Alarm release
PA_082	DI2 function configuration	2	Clockwise stroke limit
PA_083	DI3 function configuration	3	Anticlockwise stroke limit
PA_084	DI4 function configuration	5	Zero speed clamp
PA_085	DI5 function configuration	7	Speed command direction
PA_086	DI6 function configuration	11	INTSPD1
PA_087	DI7 function configuration	12	INTSPD2
PA_088	D00 function configuration	0	Servo ready
PA_089	D01 indication configuration	1	Servo alarm
PA_08A	D02 function configuration	7	Speed arrival
PA_08B	D03 function configuration	3	External brake release
PA_08C	D04 indication configuration	4	Zero speed detection
PA_08D	D05 indication configuration	5	Torque limiting

2. Related pin wiring

Signal description	Corresponding CN3 pin number	Name	Notes or supplementary notes
AGND	41	Analog ground	A ± 10 analog voltage can be input as a speed command.
AI1	42	Analog Input	

3. Related parameters

Parameter number	Parameter name	Setting range	Feature
PA_002	Control mode selection	0~5	When it is set to 1, it is the speed mode
PA_005	Internal/external speed selection	0~3	0: analog command input; 1: internal speed (internal speed 1 to 4); 2: internal speed (internal speed 1 to 3, analog command input); 3: Internal speed (internal speed 1 to 8). Note: Internal speed 1~4 corresponds to PA_053~PA_056; The internal speeds 5 to 8 correspond to PA_074 to PA_077.
PA_006	Zero speed clamp selection/speed command direction	0~2	0: Zero speed clamp signal is invalid; 1: Zero speed clamp signal is valid; 2: The speed command direction is valid (the DI port function needs to be configured). Note: Set to 2 in torque mode means that the zero-speed clamp signal is invalid.
PA_04F	Analog dead zone	0~1000	Unit: mV When the input voltage is less than the set voltage, the motor speed is zero.
PA_050	Speed command gain	10~2000	Set the proportional relationship between the input speed command and the motor speed; Set value =rotate speed of corresponding motor at 1V voltage input
PA_051	Logic negation of speed command	0~1	It is effective when PA_006≠2. When it is set to 1, the rotation is reversed.
PA_052	Speed/torque zero drift setting	-2047~+2047	Unit: mV It's used to adjust the zero drift of the input analog command.
PA_057	External analog filter	0~6400	Unit: 10uS, set analog command delay filter
PA_058	Acceleration time setting	0~2500	Set the speed mode acceleration time, unit: ms
PA_059	Deceleration time setting	0~2500	Set the speed mode deceleration time, unit: ms
PA_061	Zero speed detection threshold	10~20000	Set the detection threshold of the zero-speed detection signal (ZSP)
PA_062	The speed reaches the detection threshold	10~20000	Set the detection threshold of speed arrival signal (COIN)

4. Combination mode when using DI port to switch internal speed

DI port combination mode			Internal speed
INTSPD3	INTSPD2	INTSPD1	
0	0	0	PA_053
0	0	1	PA_054
0	1	0	PA_055
0	1	1	PA_056
1	0	0	PA_074
1	0	1	PA_075
1	1	0	PA_076
1	1	1	PA_077

5.2.3 Communication control switching internal speed

Parameter number	Parameter name	Setting range	Feature
PA_002	Control mode selection	0~5	When it is set to 1, it is the speed mode
PA_090	Work mode settings	0~1	0: External control 1: Extended control (It is set to 1 when using communication control)
PA_092	Index of communication speed mode	0~15	When the DI port is configured with the INTSPD1~INTSPD4 function, the external DI port is required to switch the multi-segment speed; When the DI port is not configured with the INTSPD1~INTSPD4 function, this parameter can be used to select the multi-segment speed. Example: When it is set to 2, the second internal speed is loaded.
PA_150	Internal speed 0	-3000~+3000	Internal speed of the 0th segment
...
PA16F	Internal speed 31	-3000~+3000	Internal speed of the 31st segment

5.3 Torque mode specification

5.3.1 Wiring diagram of torque mode

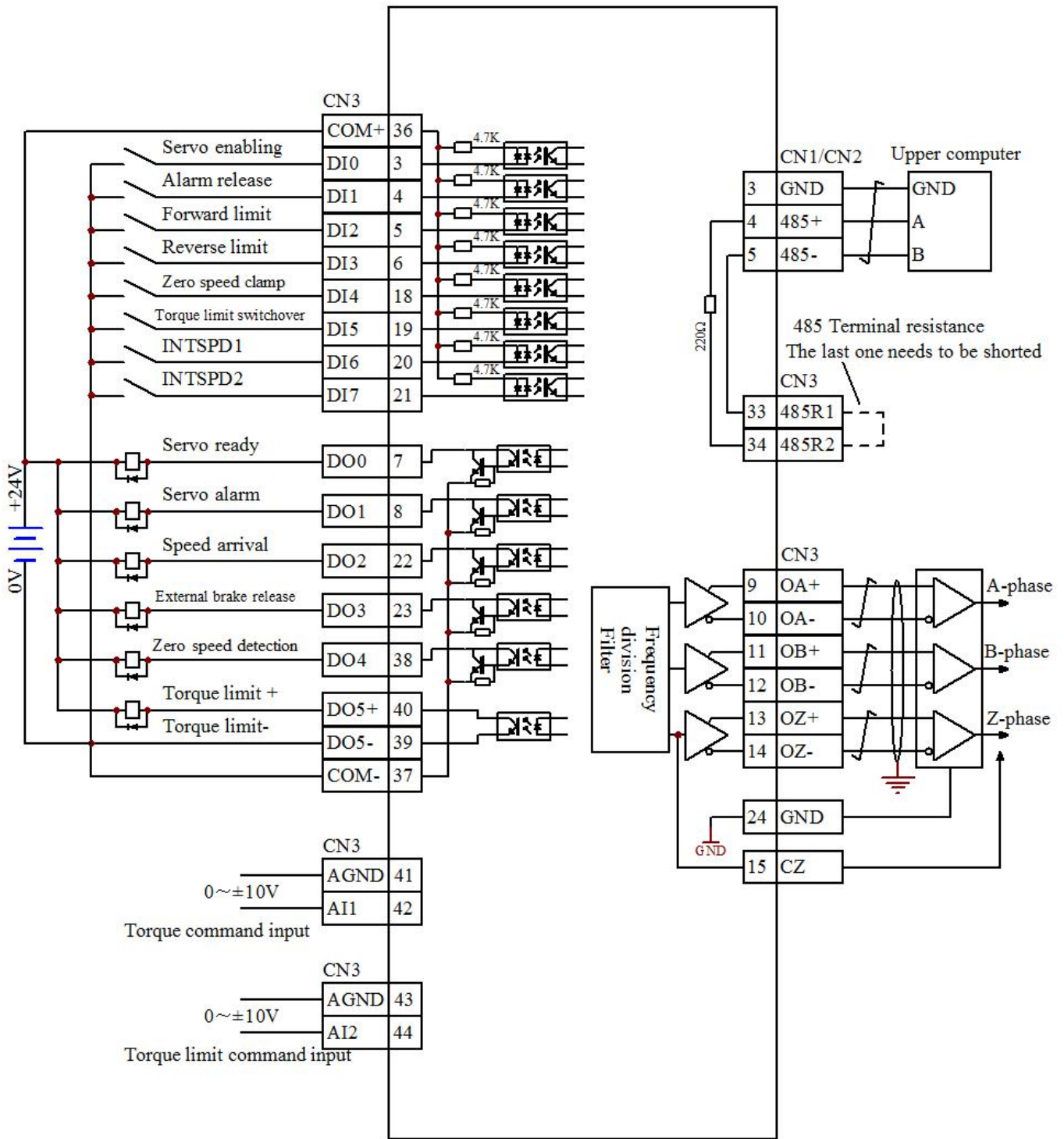

Note: When the servo is enabled, it can be controlled by the external DI port or powered on by PA_08F. The motor must be enabled before it can be controlled.

The DI port and D0 port functions of this wiring diagram are not the default configuration of the servo, and the I0 function parameters need to be modified.

5.3.2 Related functions of external torque mode

1. DI/DO port function configuration

Parameter number	Parameter name	Setpoint	Feature
PA_080	DI0 function configuration	0	Servo enabling
PA_081	DI1 function configuration	1	Alarm release
PA_082	DI2 function configuration	2	Clockwise stroke limit
PA_083	DI3 function configuration	3	Anticlockwise stroke limit
PA_084	DI4 function configuration	5	Zero speed clamp
PA_085	DI5 function configuration	15	Torque limit switchover
PA_086	DI6 function configuration	11	INTSPD1
PA_087	DI7 function configuration	12	INTSPD2
PA_088	DO0 function configuration	0	Servo ready
PA_089	DO1 indication configuration	1	Servo alarm
PA_08A	DO2 function configuration	7	Speed arrival
PA_08B	DO3 function configuration	3	External brake release
PA_08C	DO4 indication configuration	4	Zero speed detection
PA_08D	DO5 indication configuration	5	Torque limiting

2. Related pin wiring

Signal description	Corresponding CN3 pin number	Name	Notes or supplementary notes
AGND	41	Analog ground	A ± 10 analog voltage can be input as a torque command input.
AI1	42	Analog input 1	
AGND	43	Analog ground	A ± 10 analog voltage can be input as a torque limit input.
AI2	44	Analog input 2	

3. Related parameters

Parameter number	Parameter name	Setting range	Feature
PA_002	Control mode selection	0~5	When it is set to 2, it is the torque mode
PA_003	Torque limit selection	1~3	PA_003
			1
			2
			3
PA_052	Speed/torque zero drift setting	-2047~+2047	It's used to adjust the zero drift of the input analog command.(Unit: mV)

PA_057	External analog filter	0~6400	Unit: 10uS, set analog command delay filter
PA_05C	Torque command gain	10~100	Set the proportional relationship between motor torque and external analog voltage (How many volts corresponds to 100% of rated torque) Unit: 0.1V/100%
PA_05D	Torque instruction logic inversion	0~1	Set the logic level of the analog torque command.
PA_05E	1st torque limit	0~3000	Set the 1st limit value of motor torque, unit: %
PA_05F	2nd torque limit	0~3000	Set the 2nd limit value of motor torque, unit: %

5.3.3 Communication Control Torque Mode

Parameter number	Parameter name	Setting range	Feature
PA_002	Control mode selection	0~5	When it is set to 2, it is the torque mode
PA_090	Work mode settings	0~1	0: External control 1: Extended control (It is set to 1 when using communication control)
PA_093	Communication torque mode index	0~31	When the DI port is configured with the NTSPD1~INTSPD4 function, the external DI port is required to switch the multi-segment torque; When the DI port is not configured with the INTSPD1~INTSPD4 function, this parameter can be used to select the multi-segment torque. Example: When it is set to 2, the second internal torque is loaded.
PA_12C	Internal torque 0	-3000~+3000	Internal torque of the 0th segment
...
PA_14B	Internal torque 31	-3000~+3000	Internal torque of the 31th segment

5.4 Gain parameter adjustment

The first set of gain parameters is default to be valid. Generally, only the first set of gains needs to be adjusted.

Parameter address	Parameter name	Correlation Mode	Setting Range	Defaults	Function and meaning
PA_010 [16]	First position loop gain	P	0~1000	20	Define the size of the position loop gain. The gain increase can improve the servo stiffness of position control But too high a gain can cause a vibration
PA_011 [17]	First speed loop gain	ALL	1~3500	30	Define the size of the speed loop gain. The gain increase can improve the response speed or bandwidth of the speed control. Too high gain will cause vibration, so make no vibration of motor while gain increase.
PA_012 [18]	First speed loop integral time constant	ALL	1~1000	50	The action decrease can speed up the integral action and eliminates static errors faster Unit: x10uS
PA_013 [19]	First speed detection filter	ALL	0~5	1	Select the type of speed filter from 0 to 5. The higher the set value, the smaller the motor noise and the slower the response. The smaller the setting value, the faster the response. The value should be reduced if you want to increase the bandwidth.
PA_014 [20]	The first torque filter time constant	ALL	0~25000	3	Define the primary delay filter time constant after insertion into the torque command Unit: x10uS The torque filter parameters setting can reduce the vibration of the machine.
PA_015 [21]	Rate feed-forward	P	-2000~ +2000	500	It is used to set the rate feed-forward value Unit: 0.1% In the case of response height, the parameter setting can reduce the following deviation.
PA_016 [22]	Speed feedforward filter time constant	P	0~6400	50	Primary delay filter time constant for rate feedforward can be set Unit: x10uS
PA_01D [29]	First trapped wave frequency selection	ALL	25~1500	1500	It is used to set the frequency of the first trapped wave filter that suppresses resonance. 1500: Trapped wave filter function is disabled
PA_01E [30]	First trapped wave width selection	ALL	0~8	100	It is used to set the width of the first trapped wave filter that suppresses resonance. 0: The narrowest width. 8: The maximum width.

PA_021 [33]	Mechanical rigidity selection enabling	ALL	0~1	0	<p>The rigid table selection enabling configuration.</p> <p>0: PA_022 parameter setting is invalid, and gain integral and other parameters will maintain the most recent value. If the parameter is appropriate, please save the EEPROM, otherwise the power-on gain parameter will be overwritten by the EEPROM value.</p> <p>1: PA_022 parameter setting is valid, and the corresponding gain parameter can be configured according to the rigidity selection level.</p> <p>The first set of gain parameters will be covered by the corresponding values, and the covered parameters are PA_010, PA_011, PA_012, PA_013, PA_014, PA_015, PA_016.</p> <p>Note: Only the first set of gains will be affected and the second set of gains will not be covered. If the user wants to use 2 sets of gains, please adjust the parameters in a certain state, record the values; and the corresponding coverage should be converted and saved in the second set of gain parameters.</p>
PA_022 [34]	Gain mechanical stiffness rating selection	ALL	0~31	3	<p>The mechanical rigidity level can be selected, and the PA_021 good parameter must be set to 1 to be valid.</p> <p>The larger the parameter setting, the faster the response</p>
PA_026 [38]	Control method selection	P/S/T	0~1	0	<p>Choose different PID algorithms for different values.</p> <p>0: Smart PID, suitable for fast response occasions</p> <p>1: I-P control, suitable for occasions with strong rigidity requirements</p>
PA_072 [114]	Overload level	ALL	0~3000	0	<p>The overload level of the motor can be set. Unit: ‰</p> <p>If you need a lower overload level, set this parameter in advance.</p> <p>0: 1.05 times overload threshold, with overload time * 1 times</p> <p>1: 1.20 times overload threshold, with overload time * 0.875 times</p> <p>1: 1.30 times overload threshold, with overload time * 0.750 times</p> <p>3: 1.50 times overload threshold, with overload time * 0.5 times</p> <p>4: 1.20 times overload threshold, with overload time * 1 times (for special occasions)</p> <p>5: 1.30 times overload threshold, with overload time * 1 times (for special occasions)</p> <p>6: 1.50 times overload threshold, with overload time * 0.875 times (for special occasions)</p>

					<p>7: 1.05 times overload threshold, with overload time * 1.125 times</p> <p>8: 1.05 times overload threshold, with overload time * 1.250 times</p> <p>9: 1.05 times overload threshold, with overload time * 1.375 times</p> <p>10: 1.05 times overload threshold, with overload time * 1.50 times</p> <p>11: 1.05 times overload threshold, with overload time * 1.625 times</p> <p>12: 1.05 times overload threshold, with overload time * 1.75 times</p> <p>Other, overload threshold = (overload level/1000 times), overload time of 1 time</p>
PA_07D [125]	Current loop gain				Current loop gain.
PA_07E [126]	Current loop integral time constant				Unit: 62.5uS

Chapter 6 Description of parameters

6.1 Description of basic parameters

Parameter address description: The parameter number is the hexadecimal communication address with the square brackets as the decimal communication address.

Parameter address	Parameter name	Correlation Mode	Setting Range	Defaults	Function and meaning																					
PA_000 [0]	Correspondence address	ALL	0~32	1	The slave address of the communication, and 0 is the broadcast mode. Currently, it is the ModBus protocol.																					
PA_001 [1]	LED initial state	ALL	0~17	0	Select the content displayed on the 7-segment digital tube when the control power is turned on. 0: total number of position deviation pulses 1: motor speed 2: Torque output load rate 3: Control mode 4: IO signal status 5: Alarm Code / History 6: Software version 7: System status (A4 is the alarm status) 8: Discharge resistance load rate 9: Overload rate 10: inertia ratio 11: total number of feedback pulses 12: total number of command pulses 13: Total number of pulses of external feedback device deviation 14: Total number of pulses of external feedback device 15: Motor automatic identification function 16: analog command input value 17: The reason why the motor does not turn																					
PA_002 [2]	Control mode selection	ALL	0~5	0	Select the control mode of the servo drive. After the setting, it can be effective only after the control supply is powered on again <table border="1" style="width: 100%; border-collapse: collapse;"> <thead> <tr> <th>PA_002 Value</th> <th>Control modes</th> <th>pattern code</th> </tr> </thead> <tbody> <tr> <td>0</td> <td>Location modes</td> <td>P</td> </tr> <tr> <td>1</td> <td>Speed mode</td> <td>S</td> </tr> <tr> <td>2</td> <td>Torque Pattern</td> <td>T</td> </tr> <tr> <td>3</td> <td>Position/speed mode</td> <td>P/S</td> </tr> <tr> <td>4</td> <td>Position/torque mode</td> <td>P/T</td> </tr> <tr> <td>5</td> <td>Speed/torque mode</td> <td>S/T</td> </tr> </tbody> </table> <p>When it is set to the hybrid mode, the first mode or the second mode can be selected by the C_MODE (control mode switching) pin signal. C_MODE is conducting, the second mode C_MODE is not conducting, the first mode Note: It takes 10ms to input the command when switching C_MODE signal.</p>	PA_002 Value	Control modes	pattern code	0	Location modes	P	1	Speed mode	S	2	Torque Pattern	T	3	Position/speed mode	P/S	4	Position/torque mode	P/T	5	Speed/torque mode	S/T
PA_002 Value	Control modes	pattern code																								
0	Location modes	P																								
1	Speed mode	S																								
2	Torque Pattern	T																								
3	Position/speed mode	P/S																								
4	Position/torque mode	P/T																								
5	Speed/torque mode	S/T																								

PA_006 [6]	Zero-speed clamp selection	S/T	0~2	0	Select the function of the zero-speed clamp (ZEROSPD) signal. 0: Zero speed clamp signal is invalid; 1: Zero speed clamp is valid; 2: Speed command code, please configure DIx=7 (speed command direction or operate the bit7 of servo command for control), the corresponding command number is 7 instead of zero speed clamp (serial number 5) Note: In torque mode, PA_006 = 2 means the zero-speed clamp is invalid.
PA_007 [7]	Command pulse signal digital filtering	All	1~15	2	The larger the number, the stronger the anti-interference ability, and the smaller of the frequency of the input signal.
PA_008 [8]	Encoder signal digital filtering	All	1~15	2	The larger the number, the stronger the anti-interference ability, and the smaller of the frequency of the input signal.
PA_00A [10]	First trapped wave depth	ALL	any	0~99	First trapped wave depth. 0: The center frequency has the maximum attenuation and the strongest filtering. 99: the center frequency has the smallest attenuation and the weakest filtering.
PA_00B [11]	Absolute value encoder Settings	ALL	0~2	1	Choose the usage of the absolute type encoder: 0: Used as absolute type encoder 1: Used as an incremental encoder 2: Used as an absolute type encoder, with regardless of counter overflow Note: This parameter will be valid after power restarting. (Absolute encoder is not supported tentatively)
PA_00D [13]	485 baud rate setting	ALL	0~6	3	It is used to set the baud rate of RS485 0: 2400bps 1: 4800 bps 2: 9600 bps 3: 19200 bps 4: 38400 bps 5: 57600 bps 6: 115200 bps Note: This parameter will be valid after power restarting.
PA_010 [16]	First position loop gain	P	0~1000	20	Define the size of the position loop gain. The gain increase can improve the servo stiffness of position control But too high a gain can cause a vibration
PA_011 [17]	First speed loop gain	ALL	1~3500	30	Define the size of the speed loop gain. The gain increase can improve the response speed or bandwidth of the speed control. Too high gain will cause vibration, so make no vibration of motor while gain increase.

PA_012 [18]	First speed loop integral time constant	ALL	1~1000	50	The action decrease can speed up the integral action and eliminates static errors faster Unit: x10uS
PA_013 [19]	First speed detection filter	ALL	0~5	1	Select the type of speed filter from 0 to 5. The higher the set value, the smaller the motor noise and the slower the response. The smaller the setting value, the faster the response. The value should be reduced if you want to increase the bandwidth.
PA_014 [20]	The first torque filter time constant	ALL	0~25000	3	Define the primary delay filter time constant after insertion into the torque command Unit: x10uS The torque filter parameters setting can reduce the vibration of the machine.
PA_015 [21]	Rate feed-forward	P	-2000 ~ +2000	500	It is used to set the rate feed-forward value Unit: 0.1% In the case of response height, the parameter setting can reduce the following deviation.
PA_016 [22]	Speed feedforward filter time constant	P	0~6400	50	Primary delay filter time constant for rate feedforward can be set Unit: x10uS
PA_017 [23]	Acceleration feedforward	P/S	0~100	0	Acceleration feedforward coefficient
PA_020 [32]	Inertia ratio	ALL	0~10000	100	Set the ratio of the mechanical load inertia to the motor rotor inertia. Unit: % Setting value: (load inertia / rotor inertia) x 100%
PA_021 [33]	Mechanical rigidity selection enabling	ALL	0~1	0	The rigid table selection enabling configuration. 0: PA_022 parameter setting is invalid, and gain integral and other parameters will maintain the most recent value. If the parameter is appropriate, please save the EEPROM, otherwise the power-on gain parameter will be overwritten by the EEPROM value. 1: PA_022 parameter setting is valid, and the corresponding gain parameter can be configured according to the rigidity selection level. The first set of gain parameters will be covered by the corresponding values, and the covered parameters are PA_010, PA_011, PA_012, PA_013, PA_014, PA_015, PA_016. Note: Only the first set of gains will be affected and the second set of gains will not be covered. If the user wants to use 2 sets of gains, please adjust the parameters in a certain state, record the values; and the corresponding coverage should be converted and saved in the second set of gain parameters.
PA_022 [34]	Gain mechanical stiffness rating selection	ALL	0~31	3	The mechanical rigidity level can be selected, and the PA_021 good parameter must be set to 1 to be valid. The larger the parameter setting, the faster the response

PA_03D [61]	JOG speed setting	ALL	0~500	50	Set Jog speed Units: rpm																																	
PA_041 [65]	Command pulse rotation direction setting	P	0~1	0	The corresponding rotation direction and pulse form can be set according to the type of pulse command input.																																	
						<table border="1"> <thead> <tr> <th>PA_041</th> <th>PA_042</th> <th>Comm and pulse type</th> <th>Signal name symbol</th> <th>CCW command</th> <th>CW command</th> </tr> </thead> <tbody> <tr> <td rowspan="3">0</td> <td>0 or 2</td> <td>Orthogonal pulse, A, B two phases, 90 degrees difference</td> <td>PUL DIR</td> <td> <p>Phase B leads A phase for 90 degrees</p> </td> <td> <p>Phase A leads the phase B 90 for degrees</p> </td> </tr> <tr> <td>1</td> <td>CCW Pulse + CW Pulse</td> <td>PUL DIR</td> <td> </td> <td> </td> </tr> <tr> <td>3</td> <td>Comm and pulse + Positive pulse</td> <td>PUL DIR</td> <td> </td> <td> </td> </tr> <tr> <td rowspan="3">1</td> <td>0 or 2</td> <td>Orthogonal pulse, A, B two phases, 90 degrees difference</td> <td>PUL DIR</td> <td> <p>Phase A leads the phase B 90 for degrees</p> </td> <td> <p>Phase B leads A phase for 90 degrees</p> </td> </tr> <tr> <td>1</td> <td>CCW Pulse + CW Pulse</td> <td>PUL DIR</td> <td> </td> <td> </td> </tr> <tr> <td>3</td> <td>Comm and pulse + comm and direction</td> <td>PUL DIR</td> <td> </td> <td> </td> </tr> </tbody> </table>	PA_041	PA_042	Comm and pulse type	Signal name symbol	CCW command	CW command	0	0 or 2	Orthogonal pulse, A, B two phases, 90 degrees difference	PUL DIR	<p>Phase B leads A phase for 90 degrees</p>	<p>Phase A leads the phase B 90 for degrees</p>	1	CCW Pulse + CW Pulse	PUL DIR			3	Comm and pulse + Positive pulse	PUL DIR			1	0 or 2	Orthogonal pulse, A, B two phases, 90 degrees difference	PUL DIR	<p>Phase A leads the phase B 90 for degrees</p>	<p>Phase B leads A phase for 90 degrees</p>	1	CCW Pulse + CW Pulse	PUL DIR	
PA_041	PA_042	Comm and pulse type	Signal name symbol	CCW command	CW command																																	
0	0 or 2	Orthogonal pulse, A, B two phases, 90 degrees difference	PUL DIR	<p>Phase B leads A phase for 90 degrees</p>	<p>Phase A leads the phase B 90 for degrees</p>																																	
	1	CCW Pulse + CW Pulse	PUL DIR																																			
	3	Comm and pulse + Positive pulse	PUL DIR																																			
1	0 or 2	Orthogonal pulse, A, B two phases, 90 degrees difference	PUL DIR	<p>Phase A leads the phase B 90 for degrees</p>	<p>Phase B leads A phase for 90 degrees</p>																																	
	1	CCW Pulse + CW Pulse	PUL DIR																																			
	3	Comm and pulse + comm and direction	PUL DIR																																			
PA_042 [66]	Command pulse input method	P	0~3	3																																		

This parameter control power will be valid after power restarting.

PA_043 [67]	Command pulse Prohibit input settings	P	0~1	1	0: The command pulse's prohibition on terminal signal (INH) is valid; 1: The command pulse's prohibition on terminal signal (INH) is masked.														
PA_045 [69]	Feedback pulse division factor	ALL	0~32767	1	0: number of feedback pulses per revolution = encoder resolution × 4 When it is not 0: $\text{number of feedback pulses per revolution} = \frac{\text{encoder resolution} \times 4}{\text{PA}_{045}}$														
PA_046 [70]	Feedback pulse logic inversion	ALL	0~15	0	Bit0: It can set whether the logic level of the B signal output by the encoder feedback signal is reversed. 0: It is not reversed 1: Reversed (encoder A/B feedback signal) Used to set the phase relationship of the B signal with respect to the A phase signal <table border="1" style="margin-left: auto; margin-right: auto;"> <thead> <tr> <th rowspan="2">PA_046</th> <th rowspan="2">Phase A (OA)</th> <th>Motor rotates counterclockwise (CCW)</th> <th>Motor rotates clockwise (CW)</th> </tr> </thead> <tbody> <tr> <td></td> <td></td> </tr> <tr> <td>0</td> <td>Phase B (OB) It is not reversed</td> <td></td> <td></td> </tr> <tr> <td>1</td> <td>Phase B (OB) Negation</td> <td></td> <td></td> </tr> </tbody> </table> Bit1: It can set whether the logic level of the Z signal output by the encoder feedback signal is reversed. 0: It is not reversed 1: It is reversed Bit2: Selection of encoder feedback signal output content. 0: Select encoder AB signal output (The default is A/B crossover signal output) 1: Select the input pulse signal output. The A/B crossover signal shall be disabled simultaneously, the Bit0 setting is invalid with no effect on Bit1.	PA_046	Phase A (OA)	Motor rotates counterclockwise (CCW)	Motor rotates clockwise (CW)			0	Phase B (OB) It is not reversed			1	Phase B (OB) Negation		
PA_046	Phase A (OA)	Motor rotates counterclockwise (CCW)	Motor rotates clockwise (CW)																
0	Phase B (OB) It is not reversed																		
1	Phase B (OB) Negation																		
PA_048 [72]	Electronic gear ratio molecule 1	P	0~10000	1	It is used to set the frequency of the command pulse by frequency division or multiplication. Calculation formula: $\text{Number of pulses per revolution} = \frac{(\text{electronic gear ratio denominator} \times \text{encoder resolution} \times 4)}{\text{Electronic gear ratio molecule}}$ Note: Only when the parameter PA_04A is set to 0, the electronic gear ratio can take effect. The default is that the electronic gear ratio molecule 1 is effective, and it can be switched to the electronic gear ratio molecule 2 through the DI port.														
PA_04A [74]	Number of pulses required per revolution	P	0~32767	0	Directly set the number of pulses required for each revolution of the motor, The electronic gear ratio molecule and denominator parameters are effective only when the parameter is 0.														

A4 Servo Drive User Manual

PA_04B [75]	Electronic gear ratio denominator	P	1~10000	1	Refer to PA_048, electronic gear ratio molecule 1
PA_04C [76]	Smoothing filter	P	0~7	1	This parameter is only valid when PA_04D >= 512. Set the primary delay filter parameters after inserting into the pulse command. Increasing the value of this parameter further smooth the command pulse but delays the response to the pulse command. 0: The filter is invalid. 1 to 7: The filter is valid.
PA_04F [79]	Analog dead zone	S/T	0~1000	10	Set the analog dead zone, unit: mV. For example, when PA_04F = 10, When the input voltage is -10mV < Vin < +10mV, then the effective Vi is 0. When Vin < -10mv or Vin > 10mV, then effective Vi = Vin.
PA_050 [80]	Speed command gain	S	10~2000	100	It is used to set the proportional relationship between the motor speed and the external analog (AI) voltage This parameter setting value = motor speed (RPM) required when input voltage is 1V
PA_051 [81]	Speed command Logic inversion	S	0~1	0	The logic level of the input analog speed command can be set. 0: When the "+" voltage command is input, the motor rotates counterclockwise. 1: When the "-" voltage command is input, the motor rotates counterclockwise. If PA_006=2, then this parameter setting is invalid.
PA_052 [82]	Speed/torque command zero drift adjustment	S/T	-2047~ +2047	0	It is used to adjust the zero drift of the input analog (AI) command. Unit: mV
PA_057 [87]	External analog command filter	S/T	0~6400	100	Set the parameters of the primary delay filter inserted after inserting into analog speed command/analog torque command. Unit: 10uS
PA_058 [88]	Acceleration time setting	S	0~2500	100	Set the acceleration time under speed control mode. Unit: ms This parameter setting = the time required for the motor to accelerate from 0 to 1000 RPM (mS)
PA_059 [89]	Deceleration time setting	S	0~2500	100	Set the deceleration time under speed control mode. Unit: ms This parameter setting = the time required for the motor to decelerate from 0 to 1000 RPM (mS)
PA_05C [92]	Torque command gain	T	10~100	50	Set the proportional relationship between motor torque and external analog voltage (How many volts corresponds to 100% of rated torque) Unit: 0.1V/100%
PA_05D [93]	Torque command Logic inversion	T	0~1	0	Set the logic level of the analog torque command. 0: There is CCW counterclockwise torque output when inputting "+" voltage, 1: There is CCW counterclockwise torque output when inputting "-" voltage,
PA_05E [94]	1st torque limit	ALL	0~3000	2500	Set the 1st limit value of motor torque Unites: % For torque limit selection, please refer to PA_003 (torque limit selection)

A4 Servo Drive User Manual

PA_060 [96]	Positioning completed Range	P	0~20000	100	You can set the range of positioning completion, that is, the number of pulses allowed. If the number of position deviation pulses is less than this value, the positioning completion signal (COIN) has an output.
PA_061 [97]	Zero speed detection threshold	ALL	10~20000	10	The detection threshold of the zero-speed detection signal (ZSP) can be set. Units: rpm If speed consistency is detected, set the appropriate speed based on the speed command. Note: There is a 10RPM hysteresis between zero speed detection and speed consistency detection.
PA_062 [98]	Reached speed	S/T	10~20000	100	The detection threshold of speed arrival signal (COIN) can be set. Units: rpm Note: There is a 10RPM hysteresis for the detection of the arrival speed
PA_06A [106]	Mechanical brake delay when the motor stops	ALL	0~100	50	It can set the delay time from mechanical brake signal (BRK-OFF) to motor power failure when turning off the servo enable signal during stop status of motor (servo lock). Unit: x2mS
PA_06B [107]	Mechanical brake delay when the motor runs	ALL	0~100	50	It can set the delay time from mechanical brake signal (BRK-OFF) to motor power failure when turning off the servo enable signal during running status of motor (servo lock). Unit: x2mS Note: If the motor speed drops to 30 rpm before this set time, the BRK-OFF signal is turned off.
PA_071 [113]	Analog command is too large	S/T	0~100	100	It is used to set the input analog speed command, or it is used to detect whether the voltage is too high after the torque command is compensated by zero drift. Unit: x0.1V If this parameter is set to 0, the detection function for too large analog command will be canceled.
PA_07D [125]	Current loop gain				Current loop gain.
PA_07E [126]	Current loop integral time constant				Unit: 62.5uS
PA_07F [127]	Dead zone setting	ALL	1000~5000	2000	Unit: us
PA_08E [142]	I0_polarity reverse setting	ALL	-32768 ~ 32767	0	Polarity reverse setting of I0 The lower 8 bits, input the polarity setting of I0. Bit0 corresponds to DI0, Bit1 corresponds to DI1, and Bit7 corresponds to DI7. The higher 8 bits, output the polarity setting of I0. Bit8 corresponds to D00, and bit9 corresponds to bit D01.
PA_08F [143]	Servo enable mode configuration	ALL	0~2	0	0: External command or communication command enabling 1: Power-on automatic enabling

6.2 Extended Parameter Description

Number	Parameter name	Correlation Mode	Setting Range	Defaults	Function and meaning
PA_090 [144]	Control mode setting	ALL	0~1	0	Control mode setting: 0: standard mode; 1: Extended function mode (using communication control).
PA_091 [145]	Position mode index	P	0~15	0	PA_090 =1, valid in multi-segment position mode, indicating the serial number of the multi-segment position. When INTSPD1~INTSPD4 are not configured in the DI configuration, the value of this parameter can be modified by communication to achieve multi-segment position switching. In the DI parameter configuration, as long as the INTSPD1 is selected and configured, the servo internally automatically determines the index of the position according to the values of INTSPD1 to INTSPD4, and realizes the switching of the multi-segment position.
PA_092 [146]	Index of communication speed	S	0~31	0	PA_090 =1, valid in multi-segment speed mode, indicating the serial number of the multi-segment speed. When INTSPD1~INTSPD4 are not configured in the DI configuration, the value of this parameter can be modified by communication to achieve multi-segment speed switching. In the DI parameter configuration, as long as the INTSPD1 is selected and configured, the servo internally automatically determines the index of the speed according to the values of INTSPD1 to INTSPD4, and realizes the switching of the multi-segment speed.
PA_093 [147]	Torque mode index	T	0~15	0	PA_090 =1, valid in multi-segment torque mode, indicating the serial number of the multi-segment torque. When INTSPD1~INTSPD4 are not configured in the DI configuration, the value of this parameter can be modified by communication to achieve multi-segment torque switching. In the DI parameter configuration, as long as the INTSPD1 is selected and configured, the servo internally automatically determines the index of the torque according to the values of INTSPD1 to INTSPD4, and realizes the switching of the multi-torque speed.
PA_094 [148]	Absolute or relative position control Settings	ALL	0~7	0	When PA_090 =1, and this parameter is valid. Bit0: Absolute or relative position control setting. 0: Absolute position control, and position command indicates absolute position command. 1: Relative position control, and position command indicates relative position command.

PA_096 [150]	Setting of multi-segment position loading mode	P	0~2	0	PA_096	PA_094	
					0	0 (absolute position)	The load signal is always active and always loaded
						1 (relative position)	The load signal is always active and always loaded. After each load, the command source will be cleared to 0. (suitable for communication control).
					1	0 (absolute position)	PosLoad is loaded at high level, and the low position command will be held.
						1 (relative position)	Not supported (load signal is invalid)
					2	0 (absolute position)	The rising edge of PosLoad initiates a load, and other position commands remain.
1 (relative position)	The rising edge of PosLoad initiates a load, and other position commands remain.						
PA_0A0 [160]	Zeroing method configuration	ALL	0~1	0	0: homing signal; It returns to zero when the level is valid, and it stops the zero returning immediately if the level is invalid 1: Power-on automatic zero returning.		
PA_0A1 [161]	Zero returning mode	ALL	0~15	12	Note: Refer to the description of the zero returning function.		
PA_0A2 [162]	Rotate speed of high-speed searching origin signals	ALL	0~3000	300			
PA_0A3 [163]	Rotate speed of low-speed searching origin signals	ALL	0~500	50			
PA_0A4 [164]	Search for the acceleration/deceleration time of the origin	ALL	0~2500	100			
PA_0A5 [165]	Mechanical origin offset	ALL	-32768~+32767	0			
PA_0A6 [166]	Origin search timeout	ALL	0~1000	0	0: No error is reported. If it is not equal to 0, indicating the timeout period, unit: x 100mS		
PA_12C [300]	Internal torque command 0	T	-3000~3000	0	The 0th internal torque command		

.....					
PA_13B [315]	Internal torque command 15	T	-3000~3000	0	The 15th internal torque command
.....					
PA_140 [320]	Internal speed command 0	S	-3000~3000	0	The 0th internal speed command
.....					
PA_15F [351]	Internal speed command 31	S	-3000~3000	0	The 31st internal speed command
.....					
PA_168 [360]	Internal position command 0	P	any	0	The 0th internal position command
PA_169 [361]					
.....					
PA_186 [390]	Internal position command 15	P	any	0	The 15th internal position command
PA_187 [391]					
PA_190 [400]	Internal position 0 speed	P	0~3000	0	
.....					
PA_19F [415]	Internal position 15 speed	P	0~3000	0	
PA_1A0 [416]	External I0 or analog I0 selection	ALL	any	0	bit0: 0 --- select external I0, DI0 1----Select analog I0, analog I0, Sim_DI0, communication address is P1A45 Similarly, Bit1 to Bit7
PA_1A4 [420]	Communicatio n simulation I0	ALL	any	0	Bit0: The function is equivalent to external I0. It is valid when bit 0 of P1A0 is 1. Its function has P80 register configuration. Similarly, Bit1~Bit7: equivalent to DI1~DI7.
PA_1A5 [421]	Analog I0 mask	ALL	any	0	Each bit of this parameter can mask the bit corresponding to the P1A4 communication analog I0. For example, if Bit0 is 1, the bit 0 of P1A4 can be masked.
PA_1A7 [423]	Communicatio n function code	ALL	any		0x0801: ----Save all parameters (Decimal is 2049) 0x0802: ---- Clear error history(Decimal is 2050)
.....					
PA_1B6 [438]	Position instruction	ALL	any	0	Position overflow counter lower 16 bits

A4 Servo Drive User Manual

PA_1B7 [439]	overflow register	ALL	any	0	Position overflow counter higher 16 bits
PA_1B8 [440]	Command	ALL	any	0	Current instruction position is 16 bits lower
PA_1B9 [441]	position	ALL	any	0	Current instruction position is 16 bits higher
PA_1BA [442]	The user	ALL	any	0	Current user coordinates are 16 bits lower
PA_1BB [443]	coordinate	ALL	any	0	Current user coordinates are 16 bits higher
PA_1BC [444]	Position	ALL	any	0	Current feedback position is 16 bits lower
PA_1BD [445]	feedback	ALL	any	0	Current feedback position is 16 bits higher
PA_1BE [446]	Position	ALL	any	0	Current positional deviation is 16 bits lower
PA_1BF [447]	deviation	ALL	any	0	Current positional deviation is 16 bits higher
PA_1C0 [448]	Command speed	ALL	any	0	Current command speed Unit [RPM]
PA_1C1 [449]	Feedback speed	ALL	any	0	Current feedback speed. Unit [RPM]
PA_1C2 [450]	speed deviation	ALL	any	0	Current speed deviation. Unit [RPM]
PA_1C3 [451]	Command torque	ALL	any	0	Current command torque Unit [0.1%]
PA_1C4 [452]	Feedback torque	ALL	any	0	Current Feedback torque Unit [0.1%]
PA_1C5 [453]	Torque deviation	ALL	any	0	Current torque deviation. Unit [0.1%]
PA_1CB [459]	location index	ALL	0~20	0	Position index under work
PA_1CC [460]	Index of speed	ALL	0~36	0	Speed index under work
PA_1CD [461]	Torque index	ALL	0~36	0	Torque index under work
PA_1D9 [473]	Busbar Voltage	ALL	any	0	DC bus voltage. Unit [V]
PA_1DB [475]	Torque load ratio	ALL	any	0	Torque load ratio. Unit [%]
PA_1DC [476]	Resistance braking rate	ALL	any	0	Resistance braking rate. Unit [%]
PA_1DD [477]	Torque overload rate	ALL	any	0	Torque overload rate. Unit [%]

Chapter 7 Panel Display and Button Description

7.1 Introduction to the button interface

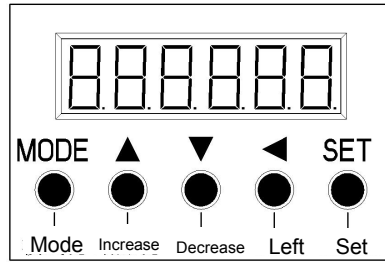

MODE	Switch among 5 modes
SET	1. It's used to switch between mode display and execution display 2. Confirm the operation
▲	Increase the value or serial number. Change the display content in the mode, change parameters, select parameters or perform selected operations
▼	Reduce the value or serial number. Change the display content in the mode, change parameters, select parameters or perform selected operations
◀	Move the movable decimal point to the left by one. (If the decimal point has reached the highest position, move it to the lowest position)

7.2 Schematic diagram of each mode switching

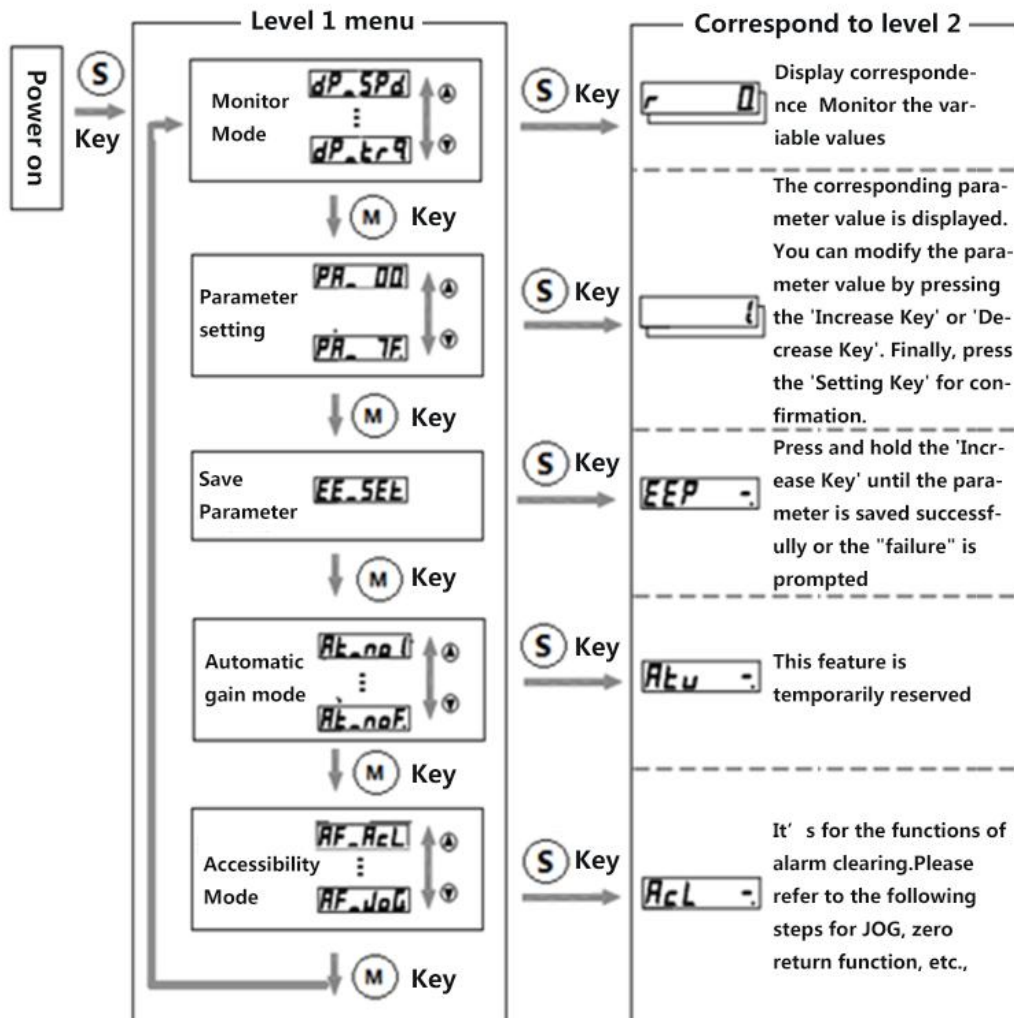

7.3 Operation instructions

7.3.1 Parameter setting

1. Enter the parameter setting mode

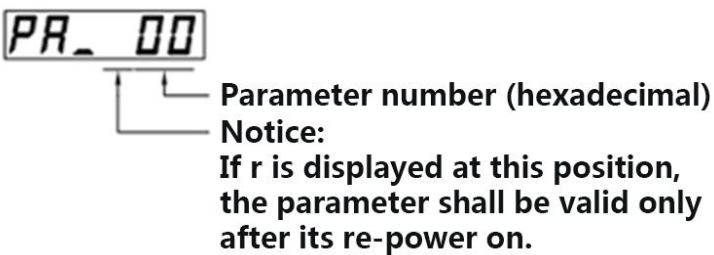

Press **(S)** key from led original state, and then press **(M)** key, then it enters the parameter setting mode

Parameter number (hexadecimal)
 Notice:
 If r is displayed at this position, the parameter shall be valid only after its re-power on.

2. Select the target parameter number

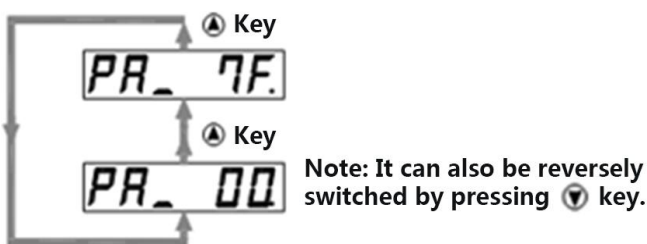

▲ Key
 ▲ Key
 Note: It can also be reversely switched by pressing ▼ key.

3. After selecting the target parameter number, press the Set key to enter the execution mode.

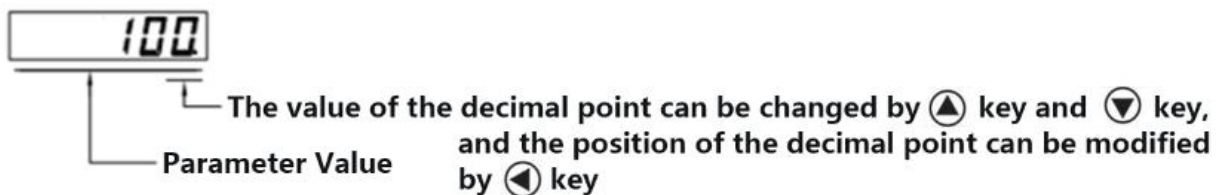

Parameter Value
 The value of the decimal point can be changed by ▲ key and ▼ key, and the position of the decimal point can be modified by ◀ key

4. Parameter saving mode (EEPROM mode)

From the Led monitor status, after pressing the Set key, press the Mode key twice to enter the parameter saving mode.

Press ▲ key until the operation is completed. There are 3 possibilities for the result, as shown on the right.

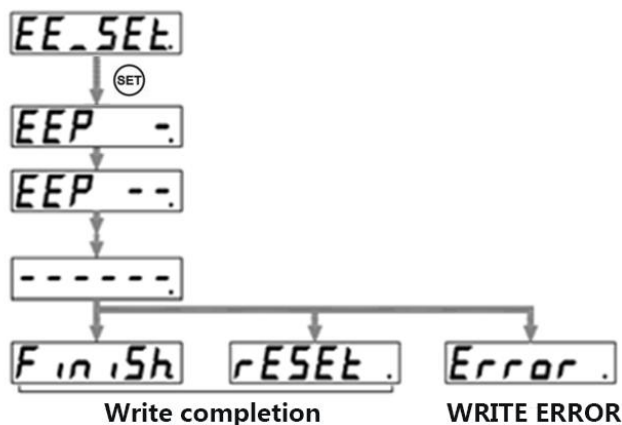

EE_5EE.
 SET
 EEP -.
 EEP --.
 ---.
 Finish Write completion
 rESEt. WRITE ERROR
 Error. WRITE ERROR

7.3.2 JOG mode

1. After entering the JOG interface and pressing the Set key, press the Mode key four times to switch to the auxiliary function Mode; and then press the "increase key" to switch to the JOG interface, as shown in the following figure:

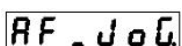

2. Press "Set" key again to enter the execution mode, as shown below



3. Keep pressing the "increase key" until the ready screen appears, as shown below.

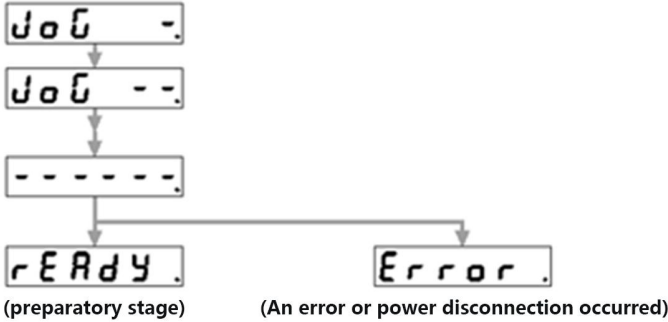

4. Keep pressing the "left shift key" until the servo enabling state appears, as shown in the figure below

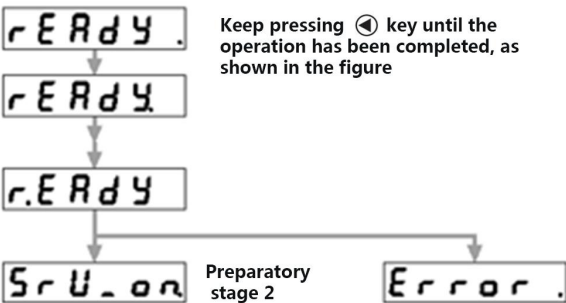

5. Rotate the motor

Press the "increase key", the motor rotates in the CCW direction at the Jog setting speed;
 Press the "decrease key", the motor rotates in the CW direction at the Jog setting speed.

7.3.3 Initialization parameter

1. After pressing the Set key, press the Mode key four times to switch to the auxiliary function Mode; and then press the "increase key" to switch to the <Restore factory parameters> interface, as shown in the following figure:



2. Press "Set" key again to enter the execution mode, as shown below



3. Keep pressing the "increase key" until the ready screen appears, as shown below.

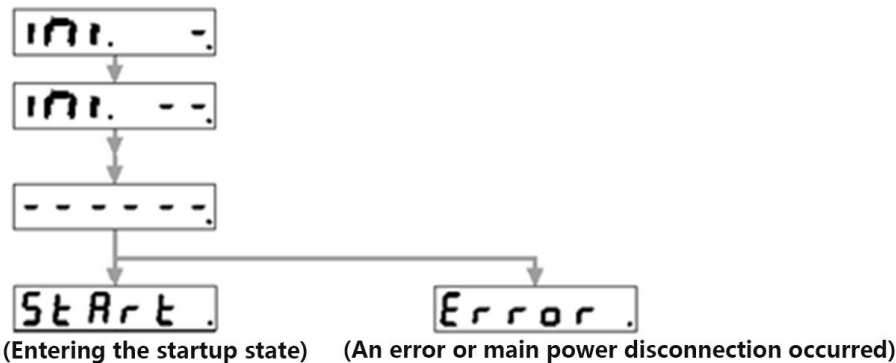

4. Keep pressing the "left shift key" until the restore parameter completion or failure status appears, as shown

in the figure below

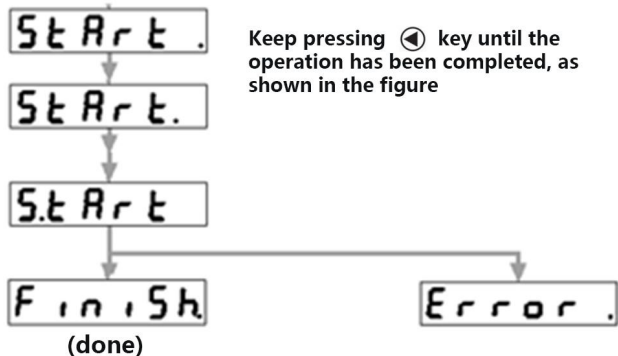

7.3.4 Alarm Clearing

1. After pressing the Set key, press the Mode key four times to switch to the auxiliary function Mode; and then press the "increase key" to switch to the <Alarm Clearing> interface, as shown in the following figure:

AF - AlL

2. Execute alarm clearing, and press "Set" key again to enter the execution mode, as shown below

AF - AlL

3. Next, keep pressing the "Increase key" until the operation is completed, as figure shown below:

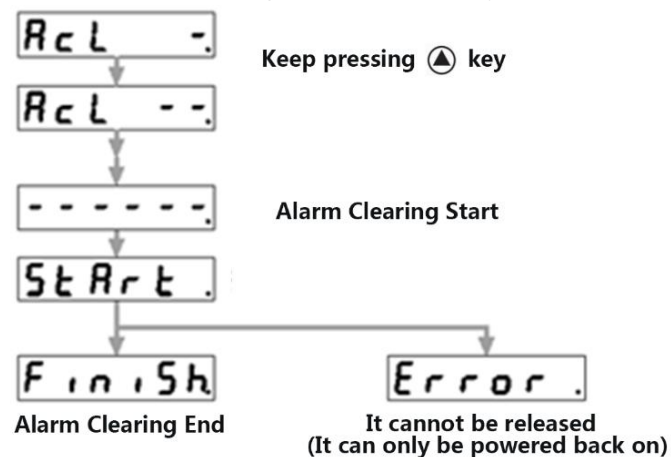

Chapter 8 Alarm Description

Protection Function	Alarm code	Cause of fault	Measure
Overvoltage	12	1. External source input voltage is much greater than 220VAC 2. Resistance braking function was not started 3. In case disconnected wiring, whether the braking resistor is damaged, and whether the brake pipe is damaged 4. Braking energy is too large	1. Replace the appropriate input power immediately 2. Check brake function (PA_06C) configuration, and reset 3. Rewire or repair 4. Increase the reduction time; replace the resistor with smaller resistance and higher power.
Undervoltage	13	1. The main power supply has no voltage but with input; the external main power input voltage is too small	1. Check if the input voltage of the power supply is correct, and correct it
Overcurrent and grounding errors	14	1. Short circuit between motor line UVW 2. Short circuit of motor line UVW and earth (metal case) 3. Hardware circuit is damaged	1. Rewire or replace the problematic cable 2. Replace the cable or replace the motor 3. Replace drives
Over heating	15	1. Use internal braking resistor with braking energy greater than 25W 2. Driver selection power is too small 3. IPM module or IGBT is damaged	1. Please use the external brake resistor and disconnect the wiring of the internal brake resistor 2. Choose a drive with higher power 3. Replace the drive
Excessive load	16	1. The actual torque is too large for a long time that exceeds the P72 set value. 2. Whether the system is vibrated 3. Accelerate too fast 4. Incorrect electrical angle measurement	1. Please check if there is any problem with the machine, causing the resistance increase, or replace the higher power drive or reduce the load. 2. Reduce system gain so that it will not cause vibration 3. Extend the acceleration time 4. Check if the power line UVW is wired or not; or whether there is any problem with the encoder
Regenerative discharge resistance overload (over-braking rate is too large)	18	1. Wiring disconnection, brake pipe damage, or brake resistor damage 2. Braking energy is too large	1. Wiring correction, or repair it 2. Replace the external braking resistor, reduce the resistance value, and increase the power. Resistance should not be less than 35 ohms; increase the reduction time, slow down speed; reduce start-stop frequency; replace drive

			with higher power or reduce load; reduce torque limit value
Encoder error	21	1. Encoder wiring problems or disconnection 2. Encoder damages 3. Interference	1. Corrected wiring 2. Replace the encoder or motor 3. Check whether the system wiring is standardized, replace the twisted pair shielded cable, and separate the coded line from the power line.
Excessive position deviation	24	1. The position command is not fast enough, and the gain is too small 2. Insufficient torque 3. Position deviation level setting is too small 4. Command pulse frequency is too high that exceeds system capability 5. The acceleration of the command is too fast 6. The motor is stuck 7. The motor itself cannot be turned	1. Check speed loop gain, position loop gain, and properly adjust them 2. Turn the torque limit value higher or replace the larger power driver 3. Turn the position deviation larger 4. Reduce the frequency of pulses 5. Reduce the acceleration of the command pulse or lengthen the acceleration time 6. Check the connection between the motor and the machine. 7. The power line UVW wiring is incorrect, or the encoder wiring is incorrect, or the encoder and motor are damaged.
Overspeed	26	1. Motor overshoot 2. The motor UVW wiring is incorrect 3. The encoder wiring is incorrect	1. The PID parameter is not properly adjusted, or the given command is close to the maximum speed (1.2 times of the rated speed) 2. Change the UVW wiring again 3. Re-update the encoder wiring
Command pulse division frequency error	27	1. The electronic gear setting is incorrect.	1. Modify the electronic gear ratio numerator and denominator
Deviation counter overflow	29	1. The motor is stuck 2. Command pulse exception	1. Check the connection between the motor and the machine 2. Command pulse exception
EEPROM parameter error	36	1. EEPROM read-write error	1. Re-restore the factory parameters, if not, the servo should be repaired
Stroke limit input signal error	38	1. If PA_003 is set to 2, and any travel limit signal is valid and an error is reported. Or if PA_003=0, the two travel	1. Check if the travel limit signal is valid; also check if the PA_08D polarity configuration of the travel

		limit signals are valid simultaneously.	limit is correct. The default invalid means that the optocoupler is not conducting, which is the opposite of the polarity of Panasonic.
Analog command overvoltage	39	1. The input analog voltage is greater than the set value of PA_071	1. Modify the PA_071 setting value (to increase the size) or reduce the external voltage command value.
system error	1	system error	1. Restore the factory parameters, if not, the drive should be repaired
DI configuration error	2	1. For PA_080 ~ PA_085 parameters, if there are two same values (except 22), then an error will be reported	1. Set the parameters differently, or 22 (invalid),
Communication Errors	3	1. Abnormal ModBus communication	1. Check if the communication line is broken; check if the main station suddenly stops accessing the servo
The control power is off	4	1. The control power is off	2. RE-POWER ON
Fpga internal error	5	1. FPGA internal error	1. Restore the factory parameters, if not, the drive should be repaired
Zeroing timeout	6	1: The origin has not been found for a long time	1. Check if the zeroing-relevant sensor input is working properly 2. Check if the zeroing mode is consistent with the current mechanical installation mode, that is, whether the zeroing mode is set correctly. 3. Encoder Z phase missing